

United States
Department of
Agriculture

Forest Service

Technology &
Development
Program

6700 Safety & Health
March 2005
0567-2819-MTDC



National Tree Climbing Guide 2005 Edition

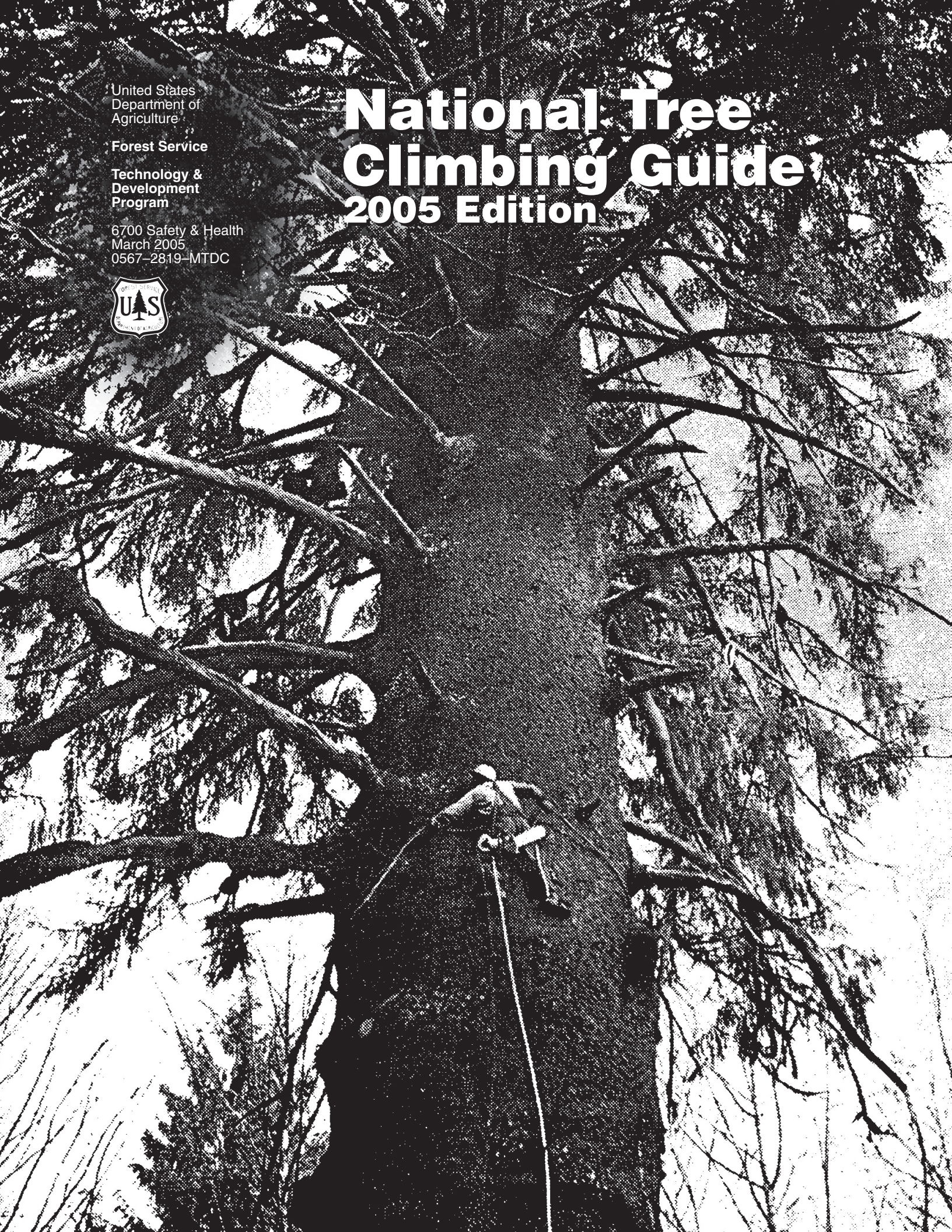

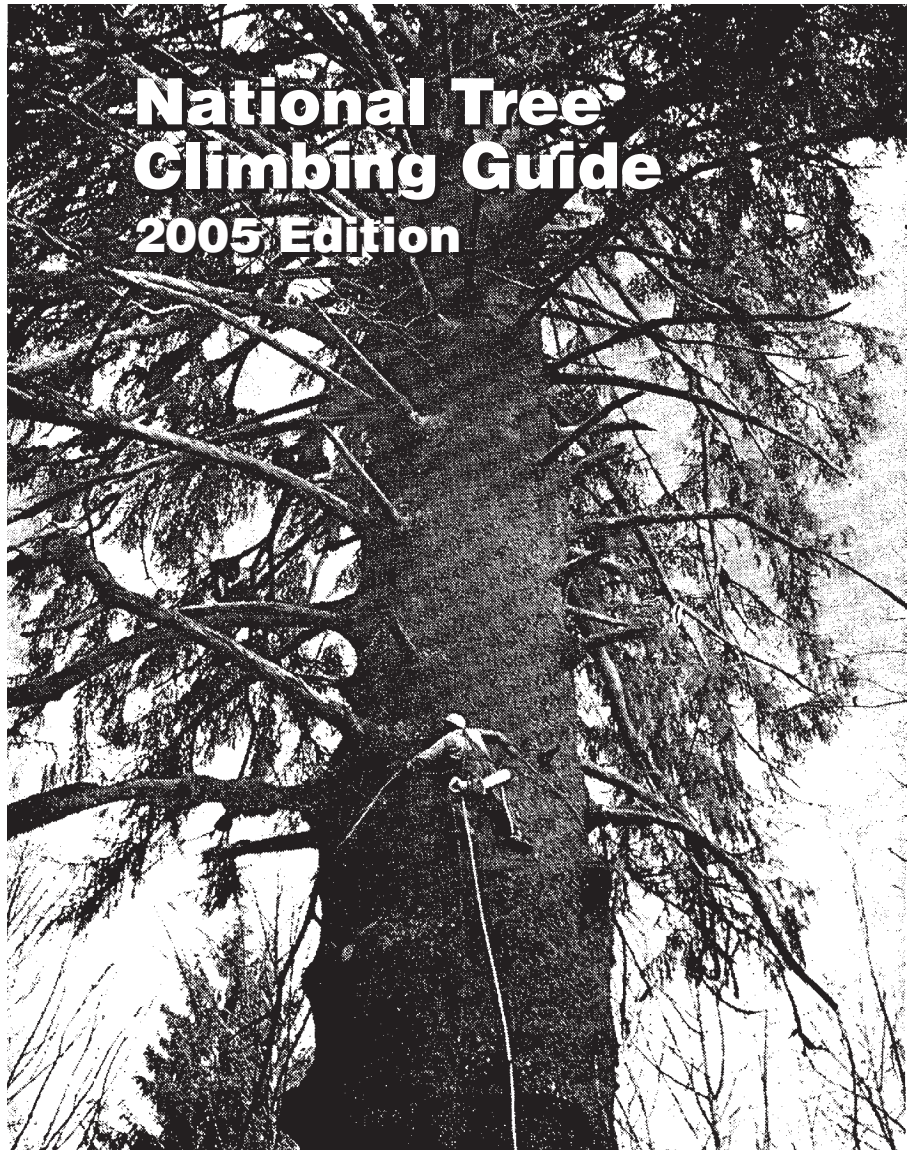

National Tree Climbing Guide

2005 Edition

Dennis Davis
Project Leader

USDA Forest Service
Technology and Development Program
Missoula, MT

TE02H23—Technical Services

March 2005

The Forest Service, United States Department of Agriculture (USDA), has developed this information for the guidance of its employees, its contractors, and its cooperating Federal and State agencies, and is not responsible for the interpretation or use of this information by anyone except its own employees. The use of trade, firm, or corporation names in this document is for the information and convenience of the reader, and does not constitute an endorsement by the Department of any product or service to the exclusion of others that may be suitable.

The U.S. Department of Agriculture (USDA) prohibits discrimination in all its programs and activities on the basis of race, color, national origin, sex, religion, age, disability, political beliefs, sexual orientation, or marital or family status. (Not all prohibited bases apply to all programs.) Persons with disabilities who require alternative means for communication of program information (Braille, large print, audiotape, etc.) should contact USDA's TARGET Center at (202) 720-2600 (voice and TDD).

To file a complaint of discrimination, write USDA, Director, Office of Civil Rights, Room 326-W, Whitten Building, 1400 Independence Avenue, SW, Washington, D.C. 20250-9410, or call (202) 720-5964 (voice and TDD). USDA is an equal opportunity provider and employer.

Acknowledgments

We would like to acknowledge the Forest Service employees whose work has helped us produce the National Tree Climbing Field Guide. Specifically, we would like to acknowledge:

Jerry Berdeen, Dorena Genetic Resource Center, Umpqua National Forest

Burnham Chamberlainø, Clackamas River Ranger District, Mt. Hood National Forest

Tyler Groo, Paulina Ranger District, Ochoco National Forest

Dale Kane, USDA Forest Service, retired

Chuck McDonnell, Quinalt Ranger District, Olympic National Forest

Dennis Ringnes, USDA Forest Service, Genetic Resource Center, Camino, CA

Donna Stubbs, Supervisor's Office, Fremont National Forest

Robert Walkowiak, Barlow Ranger District, Mt. Hood National Forest
(writer and editor of the 1996 edition)

Contents

Acknowledgments.....	ii
About the Project Leader.....	iv
1. Introduction.....	1
1.1 Training.....	1
1.2 Physical and Mental Fitness.....	1
1.3 Hazardous Duty Pay.....	1
1.4 Obtaining Climbing Equipment.....	1
1.5 Terms and Definitions.....	1
2. Preparing for a Climb.....	5
2.1 Basic Tree Climbing Equipment.....	5
2.2 Working as a Team.....	6
2.3 Checking for Hazards.....	6
3. Ropes, Knots, Splicing, and Webbing.....	11
3.1 Ropes.....	11
3.2 Knots.....	14
3.3 Whipping.....	20
3.4 Splices.....	20
3.5 Webbing.....	20
4. Climbing Safety—Equipment, Systems, and Procedures.....	23
4.1 Safety Equipment.....	23
4.2 Safety Systems.....	27
4.3 Safety Procedures.....	34
4.4 Using Explosives in Trees.....	35
4.5 Using Chain Saws in Trees.....	36
5. Climbing Equipment—Use and Care.....	39
5.1 Climbing Spurs.....	39
5.2 Ladders.....	42
5.3 Pole Steps.....	45
5.4 Swiss Tree Grippers.....	47
5.5 Ascenders.....	49
5.6 Tree Steps.....	55
6. Rappel Systems—Use and Care.....	57
6.1 Rigging and Rappelling.....	57
6.2 Sky Genie.....	60
6.3 Figure-8 Descenders.....	62
6.4 Rappel Rack.....	65
6.5 Prusik System.....	69
7. Rescue.....	73
7.1 Rescue Equipment.....	73
7.2 Rescue Procedures.....	74
8. Equipment Specifications.....	79
8.1 Carabiners and Screw Links.....	79
8.2 Climbing Belts and Safety Harnesses.....	79
8.3 Climbing Helmets.....	79

Contents

8.4 Ropes.....	79
8.5 Webbing.....	79
8.6 Miscellaneous Hardware.....	79
9. Handling Materials and Tools While in Trees.....	81
9.1 Pruning Branches	81
9.2 Harvesting Seed	82
9.3 Harvesting Scion Material for Grafting	82
10. References.....	85

About the Project Leader

Dennis Davis is the specifications engineer for firefighting equipment with the Missoula Technology and Development Center in Missoula, MT. He is a volunteer firefighter/emergency medical technician and a battalion chief for the Frenchtown Rural Fire Department in Frenchtown, MT.

1. Introduction

Climbing and working in trees demands specialized equipment and skills. The potential for a serious injury or fatal fall is always present, so employees shall be trained and certified before they engage in tree climbing operations and activities. The Forest Service Health and Safety Code Handbook and applicable State and Federal safety codes shall be followed.

This guide has been produced and edited primarily by tree climbers working in the Northwest coniferous forests. Every attempt has been made to include comments from climbers in other parts of the United States as well as climbing techniques for different types of trees. Some procedures and techniques cited in this guide do not apply to some types of tree climbing done by Forest Service employees. Each job assignment must begin with a job hazard analysis that addresses the climbing dangers associated with the job, any unusual circumstances, and the employees' plan for completing the task safely.

1.1 Training

Written materials, like this guide, play an important role in acquiring knowledge of tree climbing techniques. But no amount of reading can make a person a safe, efficient tree climber. That takes practice—practice under the guidance of an experienced and competent instructor or certified climber. Study can prepare new climbers for their initial hands-on training or provide experienced climbers with a handy review.

This guide will give you a basic understanding of the equipment and the tree climbing techniques you must master to become a competent climber. The reference list in chapter 10 provides additional sources for increasing your tree climbing knowledge.

Climbers should review the equipment manufacturers' specifications and instructions for equipment care and use.

Tree climbing assignments are accepted solely at the discretion of the climber. He or she alone is responsible for determining the advisability of climbing a particular tree, in a particular set of circumstances, on a particular day.

Work supervisors should promptly withdraw a climber's certification or remove the climber from climbing duties when the climber

- is physically or mentally unable to climb safely,
- has an unsound safety attitude, or
- has exhibited unsafe climbing habits.

1.2 Physical and Mental Fitness

Tree climbing is arduous, demanding work that requires upper body strength and overall flexibility. Besides being physically fit, you must be able to identify and compensate for any physical or mental condition that might temporarily impact your climbing ability. Compensating may mean not climbing until the condition is no longer a problem.

1.3 Hazardous Duty Pay

Tree climbing work can be hazardous and hazardous duty pay is appropriate as outlined in the Forest Service Manual.

1.4 Obtaining Climbing Equipment

With a variety of commercial equipment available, it should not be necessary to fabricate your own. Before buying any equipment, check with your regional tree climbing coordinator. Make sure equipment meets safety standards and is suitable for the intended use. Buy only from reputable dealers familiar with the equipment and its construction, materials, and breaking strengths. Several such dealers are on Government contract. Chapter 10 of this guide contains a list of some equipment manufacturers and distributors.

1.5 Terms and Definitions

Nomenclature associated with tree climbing and tree climbing equipment includes a number of commonly used terms. Sometimes, one term has several different meanings. To avoid confusion and possible climbing accidents, key terms are defined:

Field Guide Terms (Other Terms in Use)	Definitions
Anchor Point	A secure point, usually another tree, used to secure the ropes used for climbing or belay.
Ascenders (Jumars, Gibbs)	Any climbing device used to ascend a vertically fixed rope. The term ascenders usually refers to mechanical devices.

1. Introduction

Belay	A method of protecting a climber in case of an accidental fall. A safety rope tied to a climber is paid out or taken in as the climber moves by a second person (the belayer) or by the climber in a self-belay (using the 4-inch tie-in). By controlling the safety rope, the belayer can stop the climber from falling.	Climbing Helmet	Designed specifically for climbing, this helmet has a three-point chinstrap and is designed to remain in place during a fall. It is rated for the helmet's ability to protect against side and top impacts. A hardhat is not an acceptable substitute.
Carabiner (Biners, Locking Carabiners)	An oblong metal ring with a spring-loaded gate on one side used for various purposes in climbing, such as attaching equipment to the climber or securing the climber to a rappel system. Carabiners are normally produced from bar stock that is formed into the desired shape. Carabiners used in life-support applications shall be the self-closing, positive-locking type of carabiner.	Climbing Line	A rope used in tree climbing that may be used for ascending into a tree, descending from a tree, and/or working aloft in a tree.
Chest Harness	Straps placed around the chest and shoulders only to secure the proper positioning for a chest attachment point.	Climbing Spurs (Climbers, Tree Climbers, Gaffs, Pole Gaffs, Spurs, Tree Spurs, Linemans Climbers, Spikes)	L-shaped metal shanks that attach to the foot and lower leg and are used to ascend or descend a tree bole by means of a sharp spike (gaff) that penetrates the tree bark and sticks into the wood of the tree.
Chicken Loops	Sewn, tied, or buckled bands of webbing or rope that fit around the ankle to prevent the ascender slings from slipping off the climber's foot.	Climbing Team	The basic team required for all tree climbing assignments, which is made up of two or more certified tree climbers, each capable of performing the same assignment as the other. The team consists of (at a minimum) a climber and a ground person who switch roles periodically to reduce fatigue.
Climber	A person certified to climb a tree; the person climbing.	Descenders	Any rappelling device used to descend a vertically fixed rope.
Climbers Belt (Linemans Belt, Body Belt, Safety Belt)	A wide padded belt made of synthetic material usually having two large metal D-ring attachment points on the sides. A climbing belt does not have an attached chest harness.	Etrier (Step-Up Sling, Aider)	A webbing ladder or aid sling used to span distances of up to 6 feet where tree branches are missing. Usually constructed of flat or tubular webbing in a step fashion. Manufactured etriers are usually sewn to create the steps; however, knots may be used to create the steps from a length of webbing.
Climbing Harness (Safety Harness, Sky Genie Harness, Full Body Harness)	A type of harness that provides both pelvic and upper body support and can be adjusted to fit individual climbers. Climbing harnesses may be a one-piece design (full body harness) or any two-piece design that meets UIAA (Union International des Associations d'Alpinisme) or NFPA (National Fire Protection Association) standards. Climbing harnesses normally have separate leg loops. Climbing harnesses should be suitable for rescue applications. Tree climbing harnesses will usually have all of the above plus two large D-ring attachment points on the sides.	Fall Factor	Divide the length of the fall by the length of the rope in actual use. Fall factors greater than 1.0 can cause injury from the force of the sudden stop.
		Foot Lock (Secure Foot Lock)	A method of safely ascending a free-hanging rope without mechanical assistance by wrapping the rope around the feet.
		Four-Inch Tie-In	A self-belay system usually consisting of a rope, webbing, and carabiners. It

	is used as a safety line to secure the climber to the tree below the 4-inch bole diameter and at 3-foot intervals along the bole when climbing above the 4-inch bole diameter.	Belay Rope)	ground person or is attached to a firm anchor point and adjusted by the climber (such as with the 4-inch tie-in).
Ground Person	The person on the ground supporting the climber. The ground person is a certified climber who is qualified and able to perform the same climbing assignment as the person climbing. The ground person remains on the ground and must be properly equipped and ready to perform a rescue at any time.	Safety Strap (Sling)	A length of rope or webbing used as a protection point in a belayed ascent by either the ground person or the climber in a self-belay (as in the 4-inch tie-in). These straps are placed around the tree bole and secured by either a knot or carabiner, then secured to the belay rope with a carabiner.
Haul Line (Equipment Line, Tag Line, Work Line)	A small rope or cord used for raising and lowering equipment and materials to and from the climber.	Sectional Ladder (Swedish Ladder, Tree Ladder)	A specially designed ladder for tree climbing that interlocks and individually secures to the tree. This ladder comes in 10-foot sections that can be stacked to provide a continuous ladder.
Hip Thrust (Body Thrust)	A method for ascending a free-hanging rope without mechanical assistance.	Secured	A climbing system that is attached to the climber and connected to the tree that protects the climber from unintended movement. Climbers are secured when they are tied in, using a lanyard, on belay, or when they are ascending a climbing line with the footlock technique while using a Prusik loop or ascenders.
Lanyard (Safety Lanyard, Adjustable Lanyard, Prusik Lanyard, Flip Line)	A short piece of rope or webbing that secures the climber to the tree. It usually consists of an adjustable length of rope or webbing with a snap catch on each end for attaching to a climbing belt or climbing harness.	Sky Genie (Genie)	A system consisting of a special rope, a rappel device, and a tree-crotch lanyard developed for descent from a tree, either in a climbing or rescue situation.
Pole Steps	Metal steps screwed into the tree bole to make the climb easier. Steps should only be placed in trees that must be climbed often.	Snap Catch (Rope Snap, Snap Link, Snap Hook)	A metal device with a ring on one end that usually attaches permanently to a rope or cable. The other end has a spring-loaded, locking gate. Unlike the gate on a carabiner, the gate on a snap link does not lock into the body of the snap link and does not offer any additional strength when closed. Snap catches shall be the self-closing, locking type.
Rappel Rope (Main Line, Prusik Rope, Descent Rope)	A rope used to rappel or descend from a tree.	Steel Cable Lanyard	A lanyard composed of steel cable and used with the Swiss Tree Grippers.
Saddle (Sit Harness)	A type of work harness that is designed specifically to support the climber for long periods in a sitting position. A saddle differs from a safety harness by not having a chest component and may have either two separate leg loops or a single wide strap that encircles the climber below the buttocks.		
Safety Line (Safety Rope,	A rope that is either attached to a climber and used for belaying by a		

1. Introduction

Steel-Core Lanyard

(Flip Rope, Spur Rope, Cable-Core Lanyard)

A manila or nylon rope with a steel cable core in which a snap has been spliced at one end. This rope is used as a lanyard when spur climbing and when cutting, trimming, or pruning in a tree.

Swiss Tree Grippers

(Swiss Tree Climbers, Bicycles)

Specially designed tree climbing equipment used for ascending to and descending from the live crown of a tree. The set consists of two grippers (foot attachments) and a specially designed climbing belt. Each gripper consists of a foot platform and a band that wraps around the tree and grips the bole. This equipment cannot pass limbs, limb stubs, or other tree bole obstructions, so the tree must be completely pruned to either the working level or to the live crown, where the grippers can be safely removed to continue the climb in the live crown.

Tree Bole

(Bole, Tree Stem, Tree Trunk)

The main vertical part of a tree.

Tree Climbing Work

Any task performed in or on a tree where access is accomplished by means of free climbing, friction knots or mechanical ascenders, climbing spurs, bole gripping systems, permanently or temporarily mounted steps, or stacked sectional ladders.

Tree-Crotch Lanyard

(Cambium Saver Lanyard, Friction Saver)

A piece of rope or webbing designed specifically for rigging a rappel rope in a tree to reduce abrasion to the rappel rope and the tree. The lanyard is designed with an O-ring at one end and a snap catch or small-diameter ring at the other end. A double-rope rappel can be rigged so that the rappel rope does not contact the tree bole, and the rappel rope and tree-crotch lanyard can be retrieved from the ground. (see Rappel Rope).

Tree Steps

A metal, L-shaped step that attaches to the tree with a chain that is wrapped around the bole and secured to one end of the step.

Additional terms are defined and discussed throughout the guide. Become familiar with all terms associated with tree climbing work to improve communication with fellow climbers.

2. Preparing for a Climb

Your preparations shall include obtaining any special training the assignment might require, discussing with your other team member the best way to accomplish the job, and preparing a job hazard analysis for each assignment. The job hazard analysis shall include the following:

1. Analyze the assignment, then obtain the equipment needed.
2. Inspect the equipment.
3. Establish radio contact with the local forest/district office or central dispatch from the climbing site. If direct radio contact is not possible from the climbing site, an alternative method for summoning emergency help shall be established before climbing.
4. Establish a check-out and check-in procedure.
5. Assess the environment for potential hazards.
6. Assess the tree and immediate area for potential hazards.

2.1 Basic Tree Climbing Equipment

The tree climbing team must have basic equipment to accomplish any climbing assignment. Specialized equipment may also be needed depending on the nature of the assignment. The following equipment should be taken on all tree climbing assignments:

1. Team tree climbing equipment
 - A. A haul line.
 - B. A rappel rope.
 - C. A mechanical rappel device or system and compatible rappel rope (see chapter 6). A rappel system is included as basic equipment to allow a rescuer to remove an immobilized climber from the tree. The system must be capable of lowering the combined weight of a disabled climber and the rescuer. The Prusik rappel system is an alternative to a mechanical rappel system.
 - D. A rescue pack (see section 7.1 for recommended contents).

2. Individual tree climbing equipment (each person on team)
 - A. A climbing harness (climbing or saddle harness with a chest harness, or full body harness)
 - B. A climbing helmet
 - C. Two lanyards
 - D. Four locking carabiners (minimum)
 - E. A pruning saw
 - F. Eye protection

The red fire pack, available from the General Services Administration (National Stock No. 8465-01-141-2321), helps organize tree climbing gear. When carrying gear long distances, packs with more support may be more suitable. Gear should be packed the same way each time so climbers become familiar with everything and can retrieve what they need quickly. The teeth of saws and the points of gaffs should be covered. In addition, these sharp items should be stored in compartments separate from harnesses, webbing, and ropes.

3. Clothing and personal gear
 - A. Wear a long-sleeved shirt and sturdy pants or coveralls while performing tree climbing work. Clothing tends to become torn and pitchy during climbing assignments. Clothing should be loose enough to permit the extreme range of movement required for tree work.
 - B. Never wear jewelry while climbing or place anything around your neck, including cameras or extra climbing equipment.
 - C. Eye protection shall be worn.
 - D. Gloves are recommended, but not required for general climbing. Sturdy gloves, such as heavy-duty leather gloves, are a must for any rappelling.
 - E. Soft-soled footwear is recommended to reduce damage to the tree from repeated climbing. Soft-soled hiking boots, high-top tennis shoes, and crepe-soled work boots are appropriate for most tree climbing work. Logger-style boots with Vibram-type soles may be used. When working with climbing spurs, wear boots that have suitable heels to keep the spurs in place and rigid arch supports to reduce fatigue and discomfort.

2.2 Working as a Team

A climber and a ground person make up the basic climbing team. One ground person can serve several climbers, but must be able to maintain visual and voice communication with all climbers at all times. Roles are interchangeable, so all team members shall be certified climbers who are qualified to perform every aspect of the climbing assignment. All team members shall have current medical training equivalent to at least an American Red Cross basic first-aid course. The team shall establish radio communications with the forest or district office or central dispatch from the climbing site before climbing. An established sign-out system shall also be in effect with the local forest/district office or central dispatch.

All team members shall be completely equipped to climb and shall thoroughly rehearse the climbing methods and techniques they will use. Working as a team includes the following:

1. All team members shall perform an equipment check on each team member's equipment before climbing.
2. The ground person and the climber should switch roles, as necessary, to prevent undue fatigue. Alternating roles from tree to tree gives the climber an opportunity to rest. The ground person shall NOT sleep, but shall remain alert while climbers are aloft.
3. Both climber and ground person should remain alert to hazards in the tree and the environment, discussing potential problems as they arise.
4. The ground person should carefully watch the climber and communicate any problems; it is often easier for the ground person to identify hazards and recognize unsafe climbing practices than it is for the climber to do so.
5. The ground person should assist the climber by helping with harness adjustments, inspecting equipment, and attaching or removing items from the haul line.
6. The ground person should maintain verbal and visual contact with the climber. When the climber is collecting cones, the ground person should assist by pointing out areas where cones can be collected.
7. The ground person shall be prepared to perform a rescue or render first aid at all times.
8. The ground person shall not be directly underneath the climber at any time unless first cleared by the climber to be there. Whenever a ground person is underneath a climber, the climber remains in an "at rest" position until the ground person is no longer there.

2.3 Checking for Hazards

Any number of hazards may prevent a tree from being climbed. The climbing team must perform a thorough tree hazard assessment before any tree is climbed. Remember, no tree is worth a human life.

Hazards are generally grouped into two categories: environmental hazards and tree hazards. The following lists of potential hazards represent a starting point for the focus of a hazard tree assessment. In special situations where hazards cannot be mitigated, consider seeking additional help from specialists or receiving additional training before performing any work.

2.3.1 Environmental Hazards

The climbing team must assess the environmental hazards at each tree and monitor the weather throughout the day for changes that could make climbing more hazardous. Never climb a tree under any of the following conditions.

- The wind speed exceeds 25 mph or the wind is blowing in gusts. In light winds, try to keep your back to the wind. Do treetop work first, when conditions permit. If winds increase later, it may still be safe to work lower in the tree.
- It is not fully daylight. Visibility is especially important late in the day when fatigue is a factor. Do not start a tree climb that cannot be completed in full daylight.
- Air temperature is low enough to create an unsafe condition in your judgment. Be particularly aware of cold temperatures. Cold impairs dexterity, especially in the fingers, which can jeopardize your ability to accomplish tasks safely.
- A lightning storm is close. If you are in a tree when a lightning storm appears imminent, descend as quickly and safely as possible.
- A rainstorm is imminent. Wet branches are slippery. A wet rope may not be as strong as a dry one.
- A powerline is close enough to the tree that you, your equipment, or the tree branches could come in contact with the powerline. Consider any tree suspect if a powerline is anywhere in the vicinity. DO NOT climb any tree that is closer than 10 feet from energized electrical conductors.

2.3.2 Tree Hazards

Check every tree thoroughly before the climb. Both team members should walk around the tree and assess it for potential hazards. Many hazards can be compensated for easily, allowing the tree to be climbed safely. Other trees have severe hazards that preclude them from being climbed unless a special need exists, the climber is properly trained and equipped, and any hazards are mitigated. When climbing any tree, if you encounter a hazard that cannot be mitigated, descend immediately.

The following hazards may prevent a tree from being climbed, if it is not possible to compensate for them.

Rain-, ice-, or snow-covered branches. These branches pose slipping hazards that may affect climbing performance. Climbers may need to use a safety line or lanyard for added safety.

Moss and lichen. Moss and lichen create a slippery climbing surface. This hazard is especially prevalent in the Northwest. Climbers may need to use a safety line or lanyard for added safety.

Brittle limbs caused by low temperatures. Use the same precautions you would use with any brittle limbs. If the temperature is too low to climb safely, then you should not be climbing.

Tree species with brittle limbs. Test limbs for soundness before using them for support. Climbers may need to use a safety line or lanyard for added safety.

Small-diameter boles and limbs. Keep hands and feet as close to the bole as possible. When climbing above the 4-inch diameter point in conifers, a safety line shall be used. A safety line may be used earlier in the climb for added safety.

Steeply sloping limbs. Always keep your hands and feet as close to the bole as possible. Wedge them close to the bole when you are using sloping limbs for support. If your hands or feet continually slip, consider climbing with your lanyard attached at all times or use a safety line for a belayed ascent. Exercise caution on trees with branches that slope upward. To avoid getting your feet stuck, do not use them for support. If these branches cannot be avoided, consider using tree steps or using webbing slings for steps.

Damaged limbs. Never use damaged limbs to support your weight.

Branch stubs or dead branches. Never use branch stubs or dead branches for support. Remove dead branches while ascending the tree if there is a chance they might be used inadvertently while descending.

Abnormally large amounts of branch mortality.

These conditions may indicate unsafe limbs and hidden rot. This is mainly a problem in conifers.

Weak branch unions. Weak branch unions are places where branches are not strongly attached to the tree. A weak union occurs when two or more branches of similar size grow so closely together that bark grows between the branches, inside the union. This is usually a problem with branches that are growing upright. The ingrown bark does not have the strength of wood. The union is much weaker than one that has more wood. The included bark may also act as a wedge and force the branch union to separate. Elm and maple, which have a tendency to form upright branches, often produce weak branch unions. Weak branch unions also form after a tree or branch is tipped or topped (when the main stem or a large branch is cut at a right angle to the direction of growth, leaving a large branch stub). The stub inevitably decays, providing very poor support for new epicormic branches that usually develop along the cut branch.

Poor tree architecture. Poor architecture is a growth pattern that indicates weakness or structural imbalance. Trees with strange shapes are interesting to look at, but may be structurally defective. Poor architecture often arises after many years of damage from storms, unusual growing conditions, improper pruning, topping, and other damage. A leaning tree may or may not be a hazard. An arborist knowledgeable about that tree species should examine leaning trees that might be a hazard.

Forked boles and spiked top. Unless the tree species naturally forks, do not climb above a forked bole. Treat any fork with suspicion, because the fork is potentially a weak point. Never climb into a dead or spiked top. Forks sometimes indicate an old, broken top. Frequently, they are associated with wood decay, which further weakens the area, making it unsafe for climbing. Most hardwood trees fork naturally, so a forked hardwood tree would not cause as much concern as a forked conifer.

Cankers. A canker is a localized area on the stem or branch of a tree, where the bark is sunken or missing. Wounding or disease causes cankers. Stems are more likely to break near the canker. A tree with a canker that encompasses more than half of the tree's circumference may be hazardous even if exposed wood appears sound.

Cracks. Deep splits through the bark that extend into the wood of the tree are primarily a problem in deciduous trees. Cracks are extremely hazardous, because they indicate that the tree is failing. These trees should be evaluated by a person familiar with the species and climbed by certified climbers who

2. Preparing for a Climb

are properly trained and equipped for the hazards associated with the job.

Decay. A decaying tree can be prone to failure. Decay is primarily a problem in deciduous trees. The presence of decay by itself does not indicate that the tree is hazardous. Advanced decay (wood that is soft, punky, or crumbly, or a cavity where wood is missing) can create a serious hazard. Signs of fungal activity, including mushrooms, conks, and brackets growing on root flares, stems, or branches indicate advanced decay. A tree usually decays from the inside out, eventually forming a cavity. Sound wood is added to the outside of the tree as it grows. Trees with sound outer wood shells may be relatively safe, but this depends on the ratio of sound to decayed wood and other defects that might be present. If decay is evident and you have doubts about the tree, avoid it. Arborists are best qualified to evaluate the safety of a decaying tree.

Root problems. Trees with root problems may fall without warning for any number of reasons, especially when the tree's leaves grow in summer, increasing the weight the tree must support. Besides decay, roots may have a number of other problems. They may have been severed; they may have been paved over; they may have been harmed when the soil grade was raised or lowered; or a car may have driven over or parked on top of them. Mounded soil near the base of the tree, twigs that have died back, deadwood in the crown, and leaves that are offcolor or smaller than normal often are symptoms associated with root problems. Because most defective roots are underground and out of sight, aboveground symptoms may serve as the best warning.

Indications of root, butt, or bole rot. In conifers, the soundness of any tree with rot cannot be trusted. Indicators of rot include fruiting bodies of decay fungi, exposed wood that is decaying, and other indicators of internal wood decay. Wood is generally a strong material, but its strength is greatly reduced by decay. Some decay is obvious (for example, rotten wood in an exposed scar), but other decay may be hidden (for example, internal wood decay in a forked top).

Loose bark. Loose bark may peel off when grabbed for support or when spurs are used. In dead conifers, large sections of bark may break loose and fall, injuring a climber or damaging equipment. Certified climbers who are properly trained and equipped for the hazards associated with the job should do critical work in such trees.

Dead wood. Dead trees and large, dead branches are unpredictable and may fall at any time. Dead wood is often dry and brittle and cannot bend as a living tree or branch does. Dead branches or treetops that

are already broken off ("hangers" or "widowmakers") are especially hazardous. Certified climbers who are properly trained and equipped for the hazards associated with the job should do critical work in such trees.

Multiple defects. Recognizing multiple defects in a tree is critical when evaluating the tree's potential to fail. Multiple defects that are touching or close to one another should be examined carefully. The combined potential of multiple defects can far exceed the sum of the individual hazards considered separately. If more than one defect occurs on a main stem, you should assume that the tree is potentially hazardous.

Large portions of other trees or snags lodged in the crown. Trees or snags lodged in the crown of another tree may move or fall, striking the climber or pinning the climber in a tree. Tree climbing to remove these hazards, or to perform critical work in the tree, should be done by certified climbers who are properly trained and equipped for the hazards associated with the job.

Bee, hornet, or wasp colonies. Insect colonies may be in trees adjacent to the one to be climbed. Climbing may disturb the colony. Often colonies cannot be seen from the ground. When you are climbing, always let your ground person know when you spot a colony. If you cannot descend immediately and you are being attacked, secure yourself to the tree, cover your face, and don a bee hood if one is available. A can of bee and wasp spray that will stun bees, wasps, and hornets should be carried during high-risk seasons. Climbers allergic to insect stings should have the appropriate medication with them. The climbing team's first-aid kit should include an insect-sting kit, which may have to be purchased separately. Climbing to monitor or remove insect colonies should be performed only by certified climbers who are properly trained and equipped for the hazards associated with the job.

Animals in the tree. Even small chipmunks can cause enough commotion to startle a climber and create a hazardous situation. It is best to return to the tree at a later date and climb it when the animal is not present or to designate the tree as unsafe to climb without special training and precautions. Tree climbing to monitor animals, or for other animal-related activities, should be done by certified climbers who are familiar with the behavior of the animals being monitored, are properly equipped for the job, and are properly trained in the methods necessary to minimize and mitigate the associated hazards.

Large birds nesting in the tree. Be cautious of birds nesting in the tree that is being climbed or in nearby trees. Even small nesting birds can create hazardous

situations when they are threatened. If you encounter a large bird's nest, cancel the planned climbing activities for that tree and the surrounding trees. Climbing to monitor birds or their nests should be performed only by certified climbers who are properly equipped for the job and are properly trained in the methods necessary to minimize and mitigate the associated hazards.

Hazardous situations should be avoided as much as possible, unless a specific need for climbing exists. A thorough tree hazard assessment is crucial for determining the extent of the hazard and the climber's ability to deal with it. Although trainee climbers can successfully compensate for many hazards, as the severity of the hazard increases so does the level of experience required. The type or severity of a hazard may warrant additional training, specialized equipment, or outside expertise.

When climbing, if you discover a hazard that was not spotted from the ground, or that appears to be more hazardous than you originally thought, descend immediately unless the hazard can be mitigated.

2. Preparing for a Climb - Notes

3. Ropes, Knots, Splices, and Webbing

Tree climbers use different types of ropes, knots, splices, and webbing to perform their work. Each has a specific use or purpose, and you must know when, where, why, and how to use each of them appropriately. See chapter 8 for minimum rope and webbing requirements.

3.1 Ropes

The working characteristics of a rope depend on the materials used to construct it and the construction method. Not all ropes are suitable for tree climbing work. When selecting a rope, consider these points:

1. How will the rope be used—haul line, rappel line, lanyards, or 4-inch tie-in?
2. What rope properties are required for the intended use—static compared with dynamic breaking strength?
3. What type of material is best for the intended use—nylon, Kevlar, manila, polyester, or polyolefin?
4. What type of construction is best for the intended use—laid, kernmantle, or braided?

Because most tree climbing ropes are used for life support, it is critical that you be thoroughly familiar with all aspects of the rope from the time it is purchased until it is retired from service. If you are not personally familiar with the history of the rope you are going to rely on, do not use it. Purchase ropes only from reputable dealers knowledgeable about materials, construction, and breaking strengths. Never purchase used ropes.

3.1.1 Characteristics of Rope

Consider the following when selecting a rope for tree climbing work:

1. *Elasticity.* This refers to how much a rope can stretch before it reaches its breaking strength. The elongation is measured as the percentage of increase in the rope length under a given load. The amount of elongation at the breaking strength determines whether a rope is considered static or dynamic.
 - A. A static rope has less than 20-percent elongation at the breaking strength and less than 2-percent elongation at a working load of 200 pounds. As a rule, these ropes are stiffer than dynamic ropes, which can make knot tying more difficult. Generally, static ropes are more resistant to abrasion and dirt penetration. Principal uses for static ropes include haul lines, lanyards, safety straps or slings,

ascender ropes, and rappel ropes. Never use static ropes in situations where a fall could occur, such as with the 4-inch tie-in system, or as a safety line for a belayed ascent.

- B. A dynamic rope has an elongation of 40 to 60 percent at the breaking strength and less than 8-percent elongation at a working load of 200 pounds. A dynamic rope absorbs the shock of a fall, giving the climber added protection. Principal uses for dynamic ropes include safety lines and 4-inch tie-in systems. Because of their versatility, dynamic ropes are suitable for lanyards and rappelling. They are NOT recommended for haul lines or ascender ropes because of their tendency to stretch.
- C. Stretch at working loads in nylon rope:
 - A $7/16$ -inch (11-millimeter) static kernmantle rope stretches 1.5 to 2 percent of its unweighted rope length.
 - A $7/16$ -inch (11-millimeter) dynamic kernmantle rope stretches 5.5 to 7.5 percent of its unweighted rope length.
 - A $7/16$ -inch (11-millimeter) dynamic laid rope stretches 9 percent of its unweighted rope length.

Remember, these estimates refer to the stretch of the length of rope being loaded, so while a 150-foot static kernmantle rope may stretch $2\frac{1}{4}$ to 3 feet if its entire length is loaded, you may only be loading 50 feet of the rope with the remainder coiled on the ground, so the actual stretch will only be $3/4$ of a foot to 1 foot.

2. *Abrasion resistance.* Stiffer ropes generally resist abrasion better than more flexible ropes. All ropes may be abraded from within by dirt particles rubbing against the fibers or from the outside by contact with rough or sharp surfaces.
3. *Tensile strength.* Tensile strength is the resistance of a rope to a force tending to tear it apart. Tensile strength is determined by steadily applying an increasing load on a rope until it breaks.
4. *Breaking strength.* Breaking strength refers to the value at which a rope breaks when subjected to a sudden force from a known weight over a specified distance.
5. *Resistance to sunlight.* All synthetic and natural fiber ropes will deteriorate with continued exposure to sunlight. Ultraviolet degradation of synthetic rope and webbing is the most significant factor affecting the aging of rope, especially when the cordage is in storage longer than in actual use (assuming it has not been damaged). Rope made from Kevlar is especially sensitive to

3. Ropes, Knots, Splices, and Webbing

ultraviolet degradation and should be stored according to manufacturer's instructions. It is impossible to assess the strength of a rope or webbing that has been stored for long periods in direct sunlight. The cordage may be unsafe to use long before it shows any signs of wear. Rope life is easy to assess by visual and tactile inspection when it has been protected from damage and stored in a cool, dark place.

6. *Heat resistance.* Heat resistance is the ability of a rope to withstand overheating and melting due to normal or rapid (6 feet per second or more) rappelling or other friction caused by a rope rubbing against or over a surface. When heated, a rope will soften. Softening always permanently weakens the rope and may result in rope failure.
7. *Water absorption.* The more water repellent a rope the better. A rope that is wet is usually not as strong as when it is dry. A rope's abrasion resistance and tensile strength may be reduced significantly when it is wet.
8. *Chemical resistance.* Chemicals such as gasoline, bleach, acids, oils, spirits, lacquer, battery acid (including any residual acid that may be found on jumper cables), and lacquer thinner can damage ropes. Any vapors these chemicals give off may also damage ropes. Any rope that has been exposed to, or even stored near, fuels such as gasoline, diesel, or kerosene should be immediately retired from safety use in situations where the rope's failure could create a safety hazard.
9. *Aging.* Ropes have a finite service life, even if they are not used. A rope's strength decreases over time.

3.1.2 Types of Rope Materials

The type of material a rope is made of determines how it can be used in tree climbing applications. Types of rope material include:

1. *Manila.* Manila is a natural fiber that is treated with oily compounds when manufactured into rope. These oily compounds are lost as the rope ages, reducing its strength over time. Never use a plain manila rope for life-supporting lines or other important uses. Quality control is difficult because natural fibers tend to rot and degrade. Degradation occurs not only during use, but also in storage and often isn't evident on inspection. Manila rope is not as strong as nylon rope of the same diameter, and breaking strengths may vary widely depending on the manufacturer. Water absorption is high compared to synthetic fibers. Manila ropes are only suitable for utility purposes, except when combined with steel cable such as steel-core rope lanyards that

are acceptable for life-safety use. Manila ropes are considered static ropes.

2. *Polyolefin.* Ropes of polypropylene and polyethylene melt at 310 °F, but may begin to soften and weaken at 100 °F. These temperatures can be easily reached or exceeded when the ropes are subjected to abrasion and friction. Use ropes made exclusively of these materials only for haul lines or other uses that do not include life support.
3. *Nylon.* Nylon is a durable, strong, synthetic fiber with widely varying physical properties. Of the many types of nylon yarn manufactured, the two most common in rope construction are nylon 6, also known as Perlon, and nylon 6,6. Nylon 6,6 has a slightly higher melting point (500 °F) than nylon 6 (419 °F) and also a higher breaking strength; these differences, however, are not always apparent because other factors, such as rope design, contribute to the overall properties of a rope. Nylon ropes have a high breaking strength relative to their size and a high abrasion resistance when dry. Untreated, they readily absorb water, which reduces their tensile strength by up to 10 percent. Nylon ropes that have a minimum breaking strength of 5,400 pounds are suitable for climbing when they are new. Ropes of nylon may be either static or dynamic, depending on their construction.
4. *Polyester.* Dacron and Terylene are trade names for polyester fibers. This material melts at 480 °F and is not affected by water. Breaking strength is about 75 percent of similarly designed nylon 6,6 static ropes. Elasticity is about the same as manila rope. Polyester ropes are considered static ropes.
5. *Kevlar.* Kevlar is an extremely strong, high-temperature-resistant fiber. However, it has a very low elasticity and breaks if bent too tightly, such as in a knot. This type of rope is often used by rescue teams for high-angle rescues when several lives may depend on only one rope. Because of the high cost and limited life of this type of rope, it is not recommended for tree climbing applications.

3.1.3 Types of Rope Construction

The most common construction methods for rope are kernmantle, laid, and braided.

1. *Kernmantle construction.* Kernmantle rope consists of a central core (kern) of fibers that support most of the load on the rope (about 80 percent). A woven sheath (mantle) covers this core and supports less of the load (about 20 percent). The sheath's tight weave protects the core fibers from abrasion, dirt, and sunlight. The resulting rope is strong and resists damage, yet is easy to handle.

2. **Laid construction.** In laid construction, small fiber bundles are twisted together and combined into larger bundles that are twisted around one another. The “lay” of the rope is the direction in which the strands are twisted. Most ropes are right-laid (strands spiral upward to the right when the rope is held vertically). The lay may be either hard or soft. Hard-lay construction creates a stiff rope in which knots are difficult to set and hard to untie after use. When under a load, these ropes resist abrasion and hold their shape better than soft-laid ropes. Soft-lay construction results in a flexible, easy-to-use rope, but one that unwinds easily and is not recommended for rappelling. All ropes of laid construction tend to untwist when loaded, causing spin and rope kinking. The amount laid ropes untwist when loaded depends on the strength of the lay. Because each fiber may appear at the rope’s surface in several places along its length, the load-bearing fibers are more susceptible to abrasion damage.
3. **Braided construction.** Many types of braided rope are available. These ropes are gaining popularity among tree climbers because of their excellent knot holding and handling characteristics. Generally, braided ropes are softer and more flexible than kernmantle or laid ropes. However, the external fibers are susceptible to snagging, and the rope usually has a lower breaking strength compared to kernmantle or laid ropes of similar diameter.

3.1.4 Care, Cleaning, and Storage

1. A rope should never be stepped on, driven over, or have other equipment piled on it. This can grind abrasive dirt into the fibers or abrade or cut the outside surface. Sharp or heavy objects can cause unseen damage that may cause unexpected failure.
2. New rope should never be washed, rinsed, or soaked before initial use because of the naturally slippery quality that makes it soft and supple. The fibers adjust favorably, depending on use. Washing a new rope tends to remove the natural slipperiness, causing it to become dry and brittle, thereby shortening its life.
3. Rope should only be washed when very dirty. Wash ropes to keep dirt from working its way inside, where it can abrade and weaken internal fibers.
4. When a rope must be washed, check the manufacturer’s instructions. If acceptable, first soak pitchy areas with hand cleaner, then wash by hand or in a front-loading machine with mild detergent in warm water. *Drip dry out of direct sunlight; never machine dry.*
5. Proper storage maximizes a rope’s useful life. Store rope in a cool, dark, dry place. Exposure to direct sunlight rapidly deteriorates rope fibers. Untie all knots before storage and never hang a rope over a nail, small diameter peg, or hook. Ideally, rope should be coiled and stored in a rope bag that can be closed tightly.

3.1.5 Hazards

Even normal wear and tear can, over time, seriously reduce any rope’s strength. That’s why it is important to purchase only high-quality ropes and implement a documented monitoring system with frequent inspections, proper storage, and strict rope retirement standards as a way to minimize hazards. Even when using high-quality ropes, potentially hazardous situations exist in tree climbing work, including:

1. Using the wrong rope for the job.
2. Using inappropriate knots or tying knots improperly.
3. Hauling equipment up a tree or using sharp tools aloft.
4. Using a knife close to a rope under tension. A rope under tension cuts quite easily. Whenever rappelling or ascending on a rope, a knife or other sharp tool should not be used, except in an emergency when no other tool is available.
5. Bending ropes through knots or over carabiners. Bending reduces a rope’s overall strength. A rope bent in an arc that is less than four times its diameter will reduce its strength at that point by as much as 25 percent.
6. Using wet ropes.
7. Climbing or rappelling with a rope that has been driven over, used for towing, or otherwise severely damaged.
8. Using a stored rope that was damaged by animals, particularly mice.
9. Climbing with spurs—gaffs can cut rope.
10. Failing to retire stressed or seriously damaged rope.
11. Using a fixed rope being abraded by another rope passing across it, or using a fixed rope bearing against a fixed object during “bouncing” that is induced by a climber’s use of ascenders or uneven rappelling.

In situations 7 through 11, the rope should be retired even if it is new.

3.1.6 Rope Retirement

Promptly remove worn-out and unsafe ropes from climbing kits. Either cut retired ropes into lengths unusable for climbing, or permanently mark them so they won't be mistaken for ropes suitable for tree climbing work.

The service life of a rope has been the subject of much debate. The history of a rope's use and storage and the manufacturer's recommendations are important to consider when evaluating a rope's useful life. If a rope's age is unknown, it should be retired immediately and replaced. All new ropes should be marked with date of manufacture, type, and length. A log should be kept for all ropes that includes this information as well as date of purchase and type of use the rope experiences.

Check ropes carefully for surface abrasion, cuts, burns, soft or hard spots, and regions of reduced diameter. A suggested test for kernmantle rope is to form a tight bend at one end and slowly move it down the rope to the other end. Damage to the inner core of the rope will reveal itself by allowing the bend to collapse or fold more tightly at the damage point. Treat any irregularity with suspicion and take the rope out of service.

Always retire a rope when it has been subjected to any heavy stress or shock load, such as a single fall or when wear or damage becomes obvious. Retire laid ropes if the surfaces of the inner strands show substantial powdering. This is a sign of severe chemical- or storage-induced damage. Powder residue may not be retained within the strands of a soft-lay rope, so this type of damage may be hard to detect. Retire braided and laid ropes when a significant number of fibers in the yarns of the outer sheath are cut (this includes the sheath of kernmantle-constructed ropes). Whenever you are uncertain about a rope's condition, retire it. Retire kernmantle rope immediately if the kern (core) becomes damaged in any way.

3.2 Knots

Climbers should know a few specific knots and their proper use, rather than a myriad of knots that will confuse them when it is time to use one. Many knots are useful in tree climbing work, but only a few task-specific knots are essential for any given climbing technique.

Always check and test every knot you tie and, when practical, secure it with an overhand knot or other suitable safety knot. Practice knot tying at frequent intervals so correct tying becomes automatic. Knots used for tree climbing include but are not limited to:

- Figure-8 knots

- Friction knots
- Blake's hitch
- Becket hitch
- Bowline knot
- Clove hitch
- Water knot
- Grapevine knot
- Buntline hitch
- Anchor hitch
- Double fisherman's loop

3.2.1 Terms Used in Rope Work

1. *Rigging point.* The point where a rope is tied off to an object.
2. *Working end.* The end of a rope used to tie off to something.
3. *Standing part.* All the rope not fastened at the rigging point.
4. *Running end.* The end of a rope that is not rigged, or the free end.
5. *Bight.* A doubled section of rope that does not cross itself.
6. *Loop.* A turn of the rope that crosses itself.
7. *Knot.* All intentional complications in a rope.
8. *Hitch.* A means of attaching a rope to an object (such as a Becket hitch or clove hitch).
9. *Bend.* A means of fastening two ropes together (such as a figure-8 bend).
10. *Dress a knot.* To orient the rope parts of a knot so they are properly aligned, straightened, or bundled to look like the drawings. This is often necessary for proper operation of the knot or to reduce rope stress.
11. *Set a knot.* Tightening all parts of a knot so the rope parts touch, grab, and cause friction on the other parts of the knot, making the knot operational. Loosely tied knots can easily deform under strain and may fail.
12. *Working load.* About 7 percent of a rope's minimum breaking strength when used for life support; about 20 percent of its minimum breaking strength when used for other purposes.

13. *Whipping*. Tight binding around the end of a rope to prevent rope strands from unraveling.
14. *Fid*. A hard, tapering pin for separating the strands of a rope in splicing.

See figure 3a for an illustration of these terms.

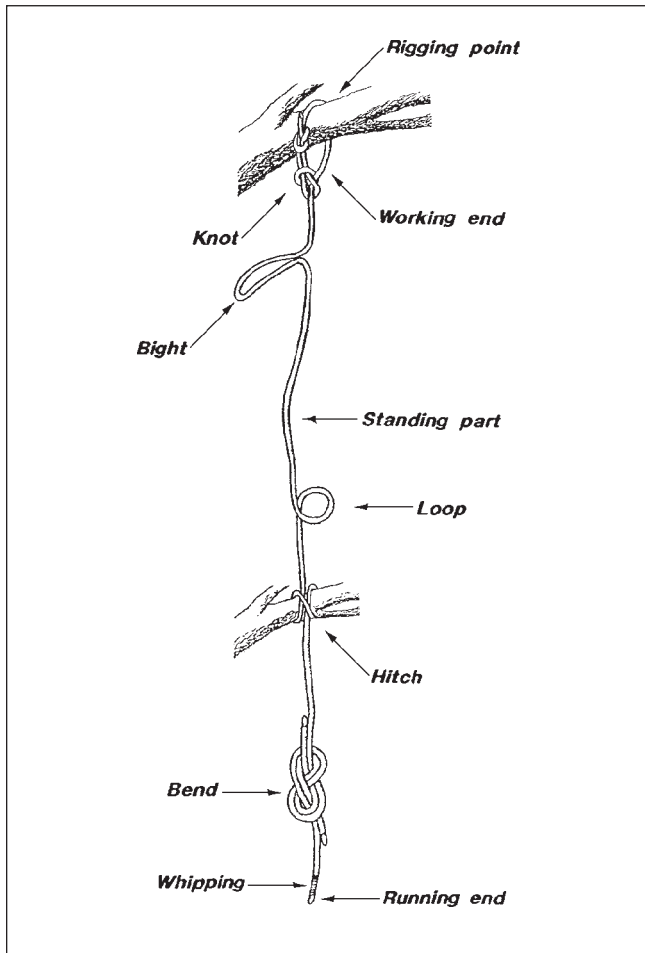

Figure 3a—Terms used in rope work.

3.2.2 Figure-8 Knots

The figure-8 knot has three useful variations, making it one of the most versatile knots for climbers. The three variations are figure eight (figure 3b), figure eight on a bight (figure 3c), and figure-8 bend (figure 3d). These variations can be used for joining two sections of rope together; attaching rope to a rigging point; attaching ropes, lanyards, or safety lines to climbers; as a safety knot on the end of rappel lines; and for many other tree climbing applications. These knots must be properly dressed and set to function safely.

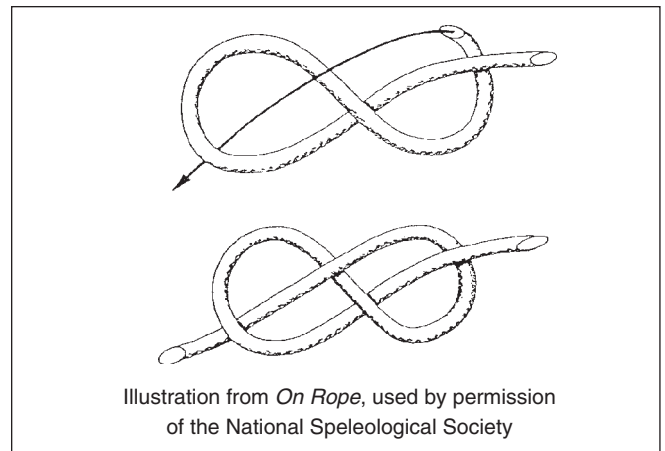

Figure 3b—Figure-8 knot.

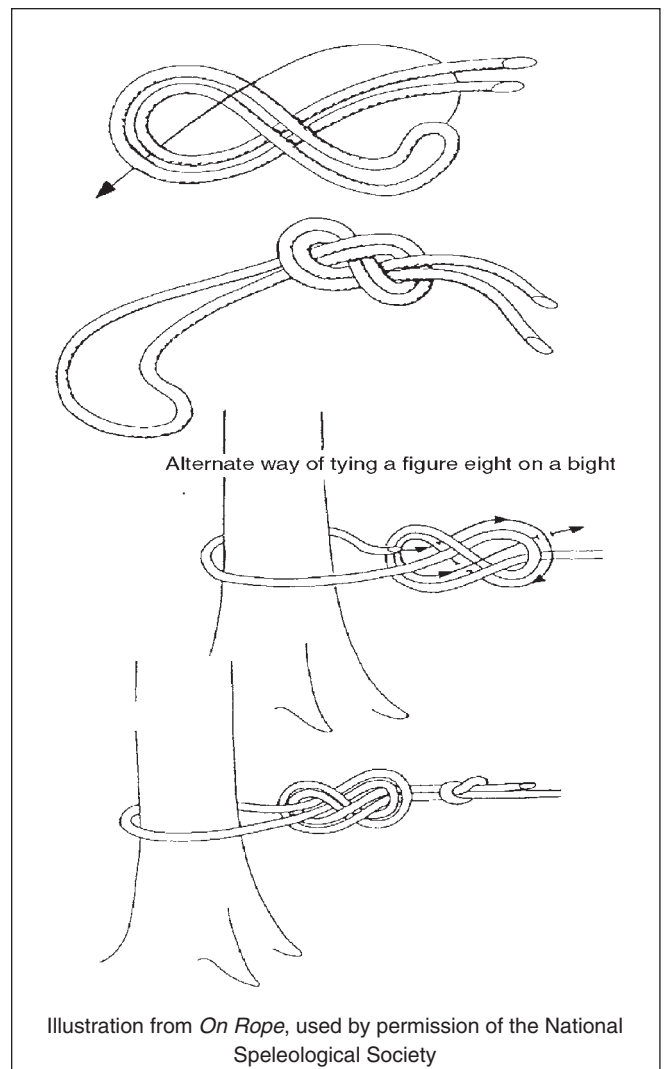

Figure 3c—Figure eight on a bight.

3. Ropes, Knots, Splices, and Webbing

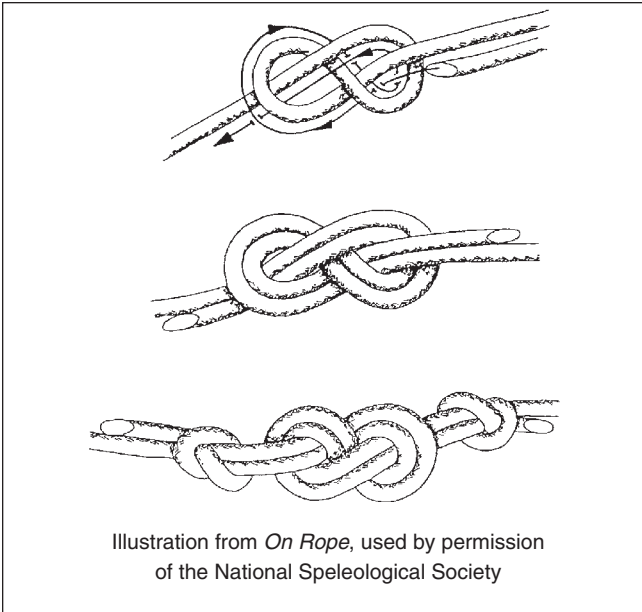

Figure 3d—Figure-8 bend.

3.2.3 Friction Knots

1. **Prusik knot.** The Prusik knot is a friction knot (figure 3e). This knot is described as a rope that is wrapped around and grips the main climbing line in such a way that it will not slide under tension. When there is no tension on the knot, it can slide freely up or down the rope. To slide the Prusik knot, push or pull on the outside wrap. Holding the entire knot adds friction, and the knot will be difficult to adjust or slide. For the Prusik knot to work properly, it must be formed from rope that is no larger in diameter than the rope on which it is being tied. Generally, a more flexible rope is used to tie the Prusik knot onto the main climbing line when solid gripping is needed; a stiffer rope is used to tie the Prusik knot onto the main climbing line when the knot must move easily. The Prusik knot has many uses in tree climbing: it is used to construct adjustable lanyards and the Prusik rappel system as well as to attach gear to rappel ropes. This knot must be dressed and set to function properly.
2. **Blake's hitch.** The Blake's hitch (figures 3f and 3g) is another friction knot and is a slight modification of the Prusik knot. It is growing in popularity because of its improved performance and because it has fewer limitations than the Prusik knot. This knot maintains more uniform friction, which provides for a smooth-running friction hitch, does not bind readily, and does not have a tendency to "roll out." The tail does not slip or creep, but is subjected to greater friction damage as it slides along the standing part of the rope. This could be a significant concern during fast rappels (which should

be avoided) or long rappels. The Blake's hitch must be dressed and set to function properly. The tail should be dressed with a figure-8 stopper knot.

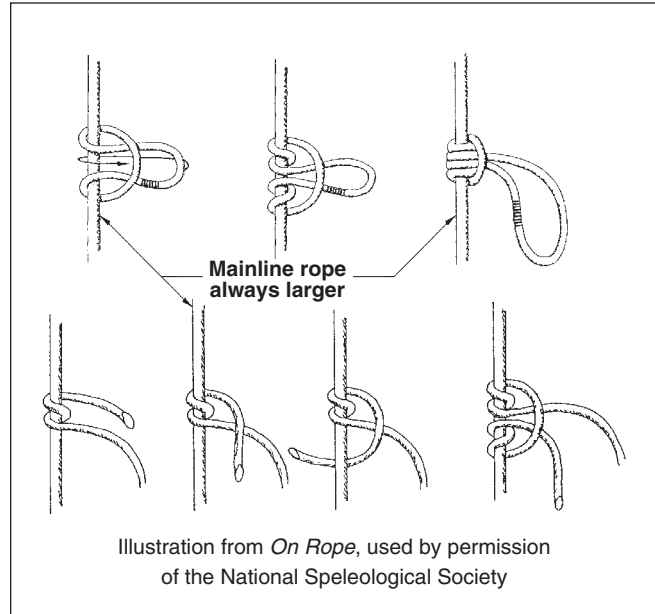

Figure 3e—Prusik knot.

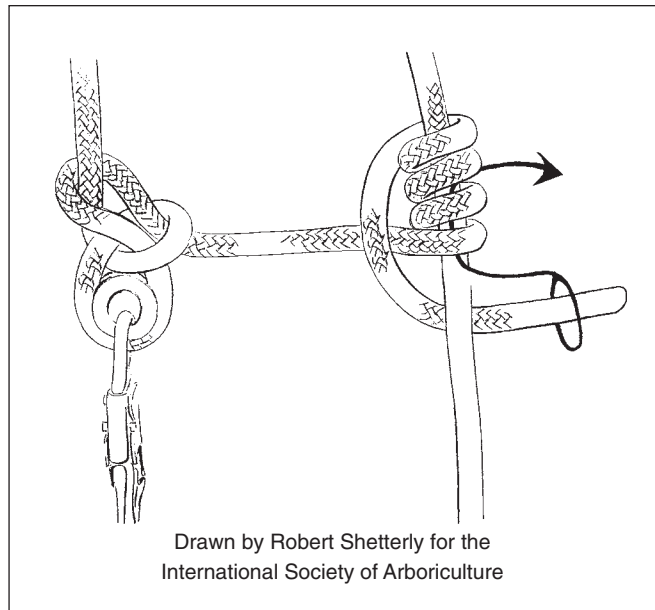

Figure 3f—Blake's hitch.

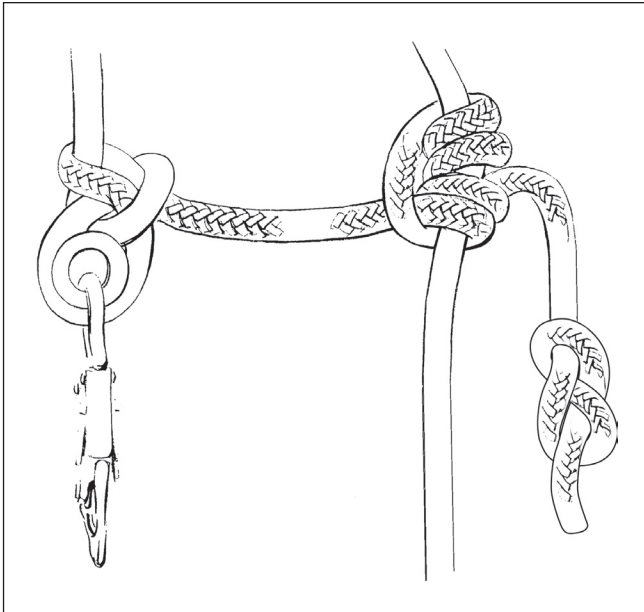

Figure 3g—Blake's hitch fully tied (a bowline knot on a snap catch).

3.2.4 Specialty Knots

Becket hitch. The Becket hitch is a specialty knot that is used with steel-core rope when attaching the rope to the D-ring of a climbing belt or safety harness (figure 3h).

CAUTION: Do not use this hitch with soft or flexible ropes.

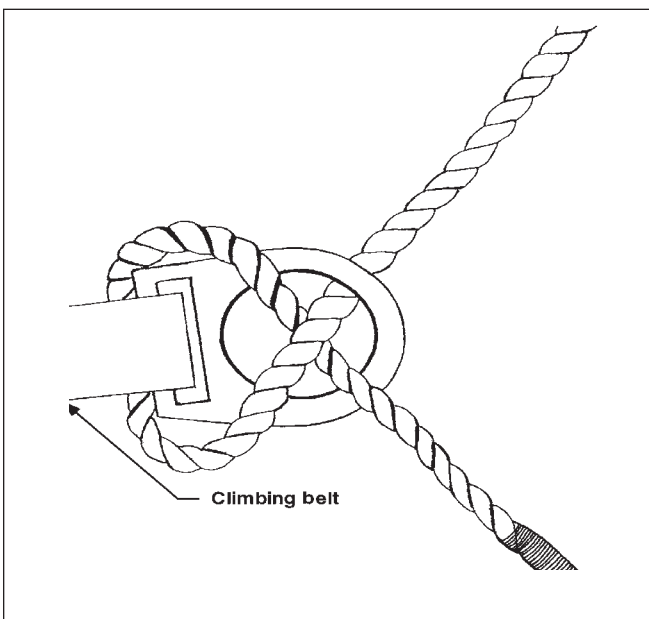

Figure 3h—Becket hitch.

3.2.5 Other Useful Knots

Other useful knots for tree climbing include the bowline, clove hitch, water knot, grapevine, buntline hitch, anchor hitch, and double fisherman's loop. The selection of these knots, as with other knots referenced, is based on their utility and safety.

Bowline knot. The bowline forms a nonslipping loop at the end of a rope (figure 3i). This knot must be dressed and set to function properly.

Clove hitch. The clove hitch is used to temporarily attach tools and materials to a rope or tree (figures 3j, 3k, and 3l). The clove hitch is NOT suitable for life support.

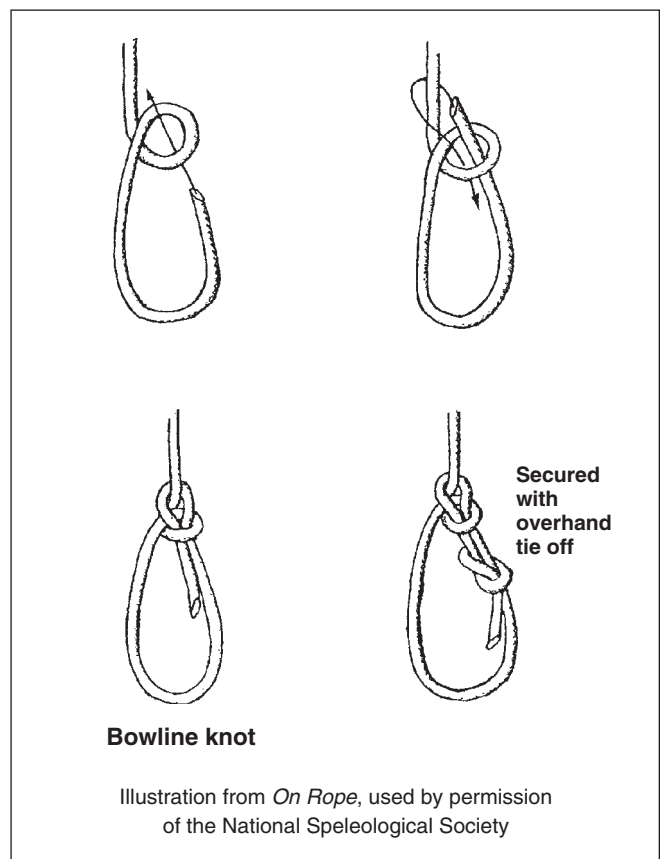

Figure 3i—Bowline knot.

3. Ropes, Knots, Splices, and Webbing

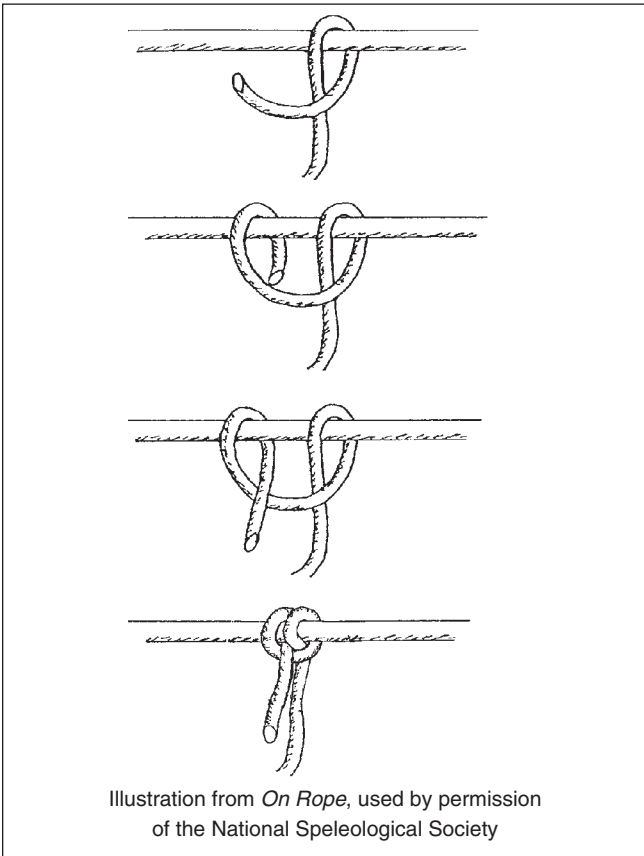

Figure 3j—Clove hitch.

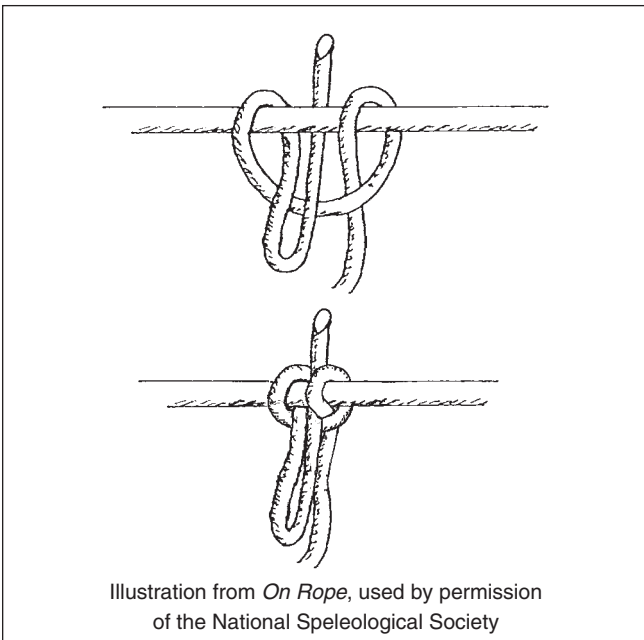

Figure 3k—Tucked clove hitch.

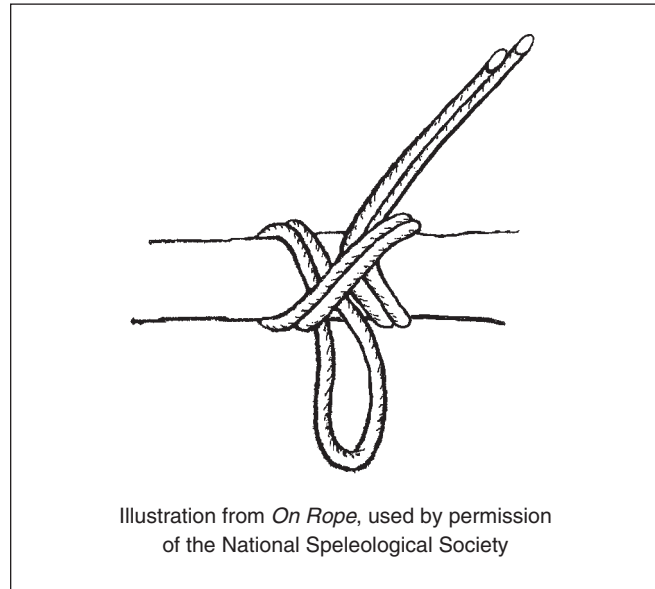

Figure 3l—Clove hitch on a bight.

Water knot. The water knot is used to join two ends of webbing together (figure 3m). *This knot is the best knot for securing webbing and should only be used with webbing.* It must be dressed and set to function properly.

CAUTION: This knot must have adequate tails (3 inches or longer) and should be carefully inspected before each use, as it will loosen due to the nature of webbing.

Grapevine knot. The grapevine knot is another good knot for joining two rope ends together (figure 3n). **DO NOT** use with webbing. This knot must be dressed and set to function properly.

Buntline hitch. The buntline hitch (figure 3o) is used to attach a climbing line or lanyard to a life-support device such as a carabiner or snap hook. Dress and set the hitch for proper function.

Anchor hitch. Use the anchor hitch to secure the climbing line to a carabiner or snap hook (figure 3p). Dress and set the hitch for proper function.

Double fisherman's loop. This knot also is used as an end-line attachment knot for a carabiner or snap hook. The buntline hitch, anchor hitch, and double fisherman's loop all snug down, capturing the attachment device and preventing unwanted movement at the attachment point (figure 3q). Dress and set the knot for proper function.

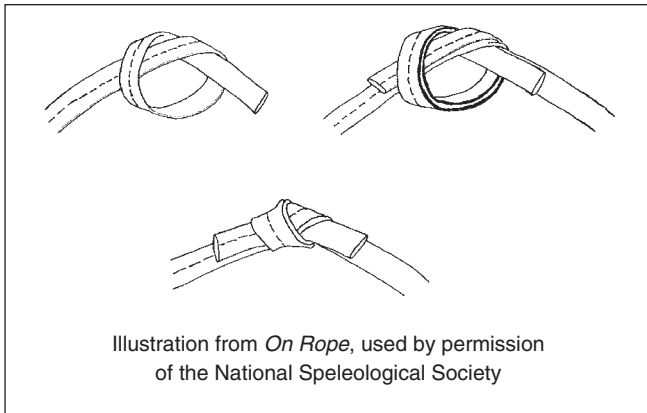

Figure 3m—Water knot.



Figure 3o—Buntline hitch.

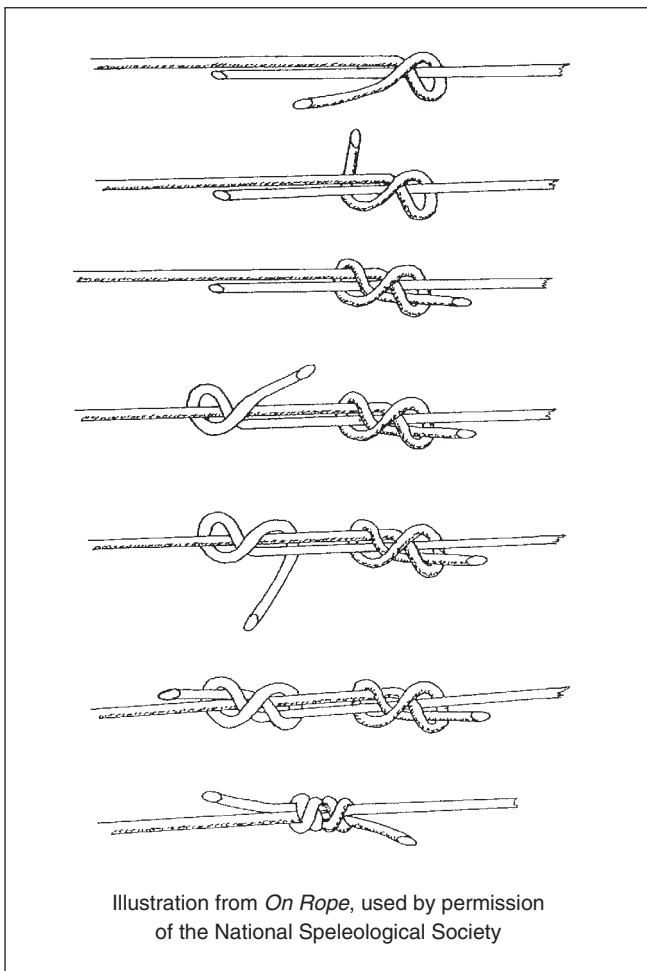

Figure 3n—Grapevine knot.

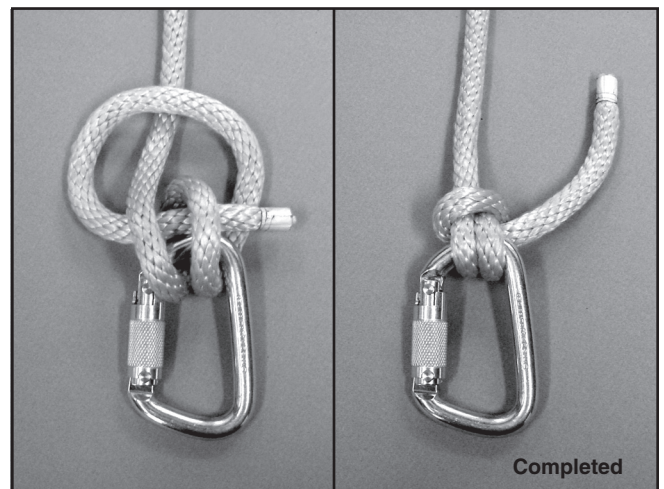

Figure 3p—Anchor hitch.

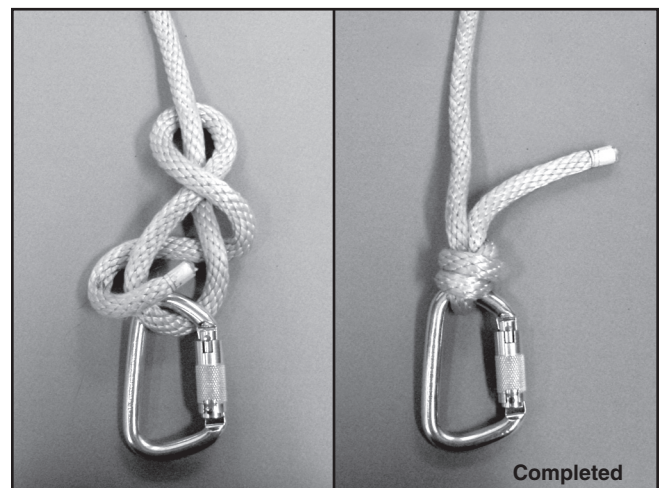

Figure 3q—Double fisherman's loop.

3.3 Whipping

To prevent fraying, the ends of synthetic rope of laid construction should be heat sealed, then whipped (figure 3r). With kernmantle ropes, it is only necessary to heat seal the rope ends. The ends of natural fiber rope should be whipped but not heated.

The following procedure may be used to whip rope ends with twine:

1. Hold the end of the rope in front of and pointing away from the body.
2. Lay small-diameter twine, preferably waxed linen, along the end of the rope and form a bight over the end of the rope.
3. Bring the standing part of the twine back along the rope for approximately 1 inch.
4. Firmly wind the standing part around the rope to within approximately $\frac{1}{4}$ inch of the rope end.
5. Pass the standing part through the bight at the end of the rope.
6. Pull the running end until the bight is drawn about midway down inside the wound twine.
7. Carefully trim the loose ends of twine.

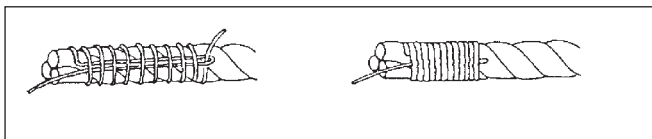

Figure 3r—Whipping with twine.

NOTE: When proper twine is not available, duct tape may be used as a temporary alternative to whipping (figure 3s).

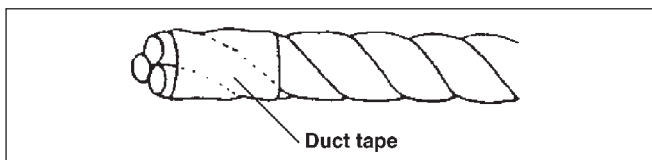

Figure 3s—Whipping with duct tape.

3.4 Splices

No splice is as strong as the rope itself, but a well-made splice is significantly stronger than a knot. Properly splicing ropes takes experience, skill, and practice. Because of the diverse types of equipment available commercially, it

should not be necessary to use homemade splices in life-safety applications. Should splicing be necessary for other applications, many books are available that provide detailed instructions.

3.5 Webbing

Webbing is a form of flat cordage that comes in many different sizes and types. Wider webbing is generally stronger, but due to differences in construction and materials, width is not always a good indication of breaking strength. It is essential to know the breaking strength of any material used in tree climbing work. The climber is responsible for purchasing webbing that meets or exceeds approved safety standards.

Heavy-duty webbing that is 2 to 3 inches wide is available. Heavy-duty flat webbing may be difficult to handle or tie securely. Tubular webbing is usually stronger and more flexible than a similar width of flat webbing. Quality 1-inch tubular webbing usually has a breaking strength of about 4,000 pounds. This webbing will only meet life-support strength requirements when assembled and used as a loop sling (figure 3t).

Two types of construction are used for tubular webbing:

- Spiral structure, also referred to as shuttle loom construction. This type of webbing is suitable for life support.
- Chain structure, also referred to as edge-stitched or needle-loom construction. This type of webbing is NOT suitable for life support (see section 8.5).

Most webbing on the market is constructed with a chain structure that is more susceptible to abrasion damage from rough surfaces or sharp edges. If a critical thread in the chain is pulled out or cut, this webbing tends to unravel and may fail.

Recent advances in webbing technology have resulted in a new class of tubular webbing (class 1A, tubular needle-loom webbing of MIL-W-4088, Webbing, Textile, Woven Nylon) that is constructed with a special, double-thickness lock stitch that prevents unraveling. Climbers should thoroughly research webbing products before purchasing them because unused equipment can rarely be returned.

To determine how a particular piece of tubular webbing is constructed, open the “tube” of the webbing and flatten it by laying the edge crease flat (figure 3u). If the crease forms a distinct irregularity at the edge where a chain stitch joins the two sides of the webbing, then it is a chain structure. The spiral variety has no such stitch, and the ribbed appearance of the surface spirals continuously across the webbing edge.

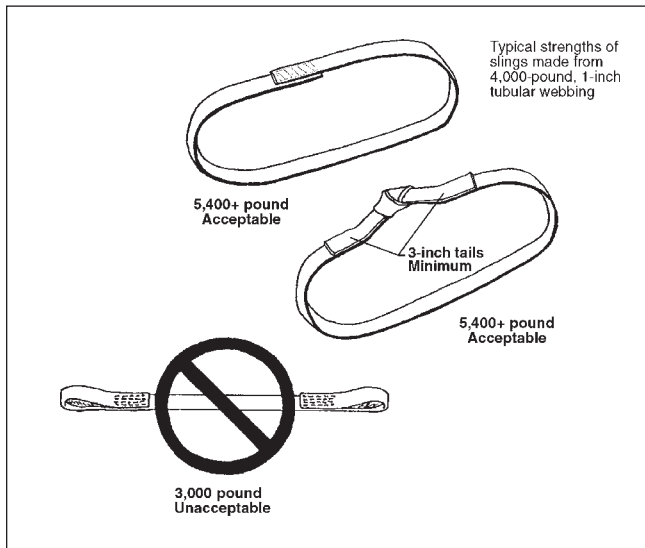

Figure 3t—Sling construction using webbing.

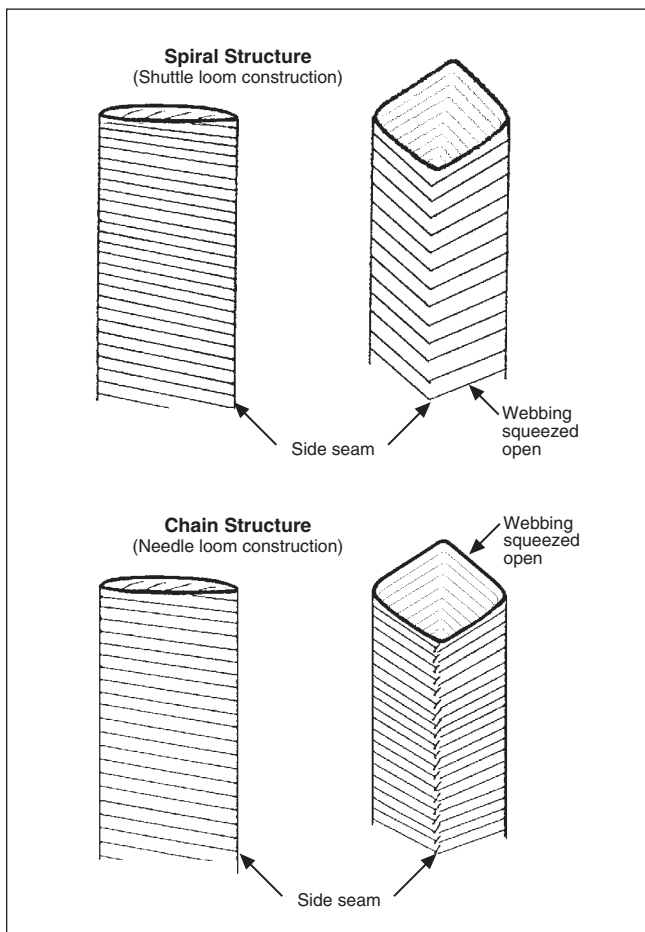

Figure 3u—Webbing construction.

3.5.1 Suitable Uses for Webbing

- Safety straps for protection points in the 4-inch tie-in system
- Safety straps for protection in belayed climbing
- Step-up slings (etriers)
- Utility cordage for attaching and hauling equipment aloft
- Tree-crotch lanyard

3.5.2 Advantages of Webbing

- Worn webbing is less expensive to replace than worn rope and is more convenient.
- Webbing may be used to keep climbing rope away from points of wear and contamination.
- Tubular webbing is extremely flexible, making it easy to handle. It is relatively resistant to breaking over rounded edges (such as carabiners and branches), and it generally withstands abrasion well.

3.5.3 Disadvantages of Webbing

- Webbing does not have a protected core like a kernmantle rope, so the load-bearing elements are directly exposed to abrasion and ultraviolet deterioration.
- Webbing is more vulnerable to cutting when exposed to sharp edges.

3.5.4 Care, Cleaning, and Storage of Webbing

1. Never wash, rinse, or soak new webbing before initial use. New webbing is naturally slippery, which makes it soft and supple. Washing new webbing tends to remove the natural slipperiness, causing it to become dry and brittle and shortening its life.
2. Dirt will damage webbing over time through abrasion. When necessary, wash dirty webbing in warm water with mild detergent to reduce the likelihood of abrasion.
3. Avoid heat and direct sunlight when drying webbing.
4. Before storing, remove knots if webbing is to be retied in different configurations in the future. If webbing is tied in a permanent configuration (such as safety straps and etriers), leave knots in place to help them “set.”
5. Store webbing in a cool, dark, dry place.

3. Ropes, Knots, Splices, and Webbing

6. Never store webbing where it can be stepped on or have equipment piled on top of it; this can cause internal wear by grinding abrasive dirt into the fibers or direct damage by abrasion or cutting.
7. Examine fibers closely for wear. Retire webbing before 30 percent of the surface fibers are worn at any place along the webbing.
8. Keep webbing used for life support separated from utility cordage. Mark utility cordage so it can be distinguished from material used for life support.
9. Never use life-support webbing for vehicle towing or subject it to other such abuse.

3.5.5 Hazards of Webbing

The cumulative effects of wear and exposure to unfavorable conditions can seriously reduce the safety margin of any webbing. It is important to emphasize the need for new, carefully monitored, high-quality materials in tree climbing work. Frequent inspection and strict retirement standards are essential. To minimize hazards:

1. Use webbing only in applications where a static rope would be appropriate. Webbing is not designed to absorb dynamic loading.
2. Make sure any webbing used for life support is constructed of nylon or polyester and applied in a manner that provides a minimum breaking strength of 5,400 pounds. "Spectra" webbing is a suitable alternative to standard webbing where exceptional strength with less weight and bulk is needed.
3. Commercially sewn slings for rock climbing with breaking strengths in excess of 5,400 pounds are recommended for tree climbing.

Commercial products not designed explicitly for life support applications are not acceptable substitutes, nor are "homemade" slings.
4. A tied sling using the water knot is an acceptable substitute for commercially sewn slings. The knot must have adequate tails (3 inches or longer) and be smooth, tight, and secure (properly dressed). Carefully inspect the knot before each use.
5. Surface wear should be taken seriously in webbing products.
6. Avoid situations where a running line may abrade or cause friction heating of webbing. This may lead to rapid wear or sudden failure.
7. Not all webbing is suitable for tree climbing work because of its breaking strength or type of construction (see section 8.5).

4. Climbing Safety—Equipment, Systems, and Procedures

Climbing and working in the live crown of trees requires specialized equipment and techniques. You must be thoroughly familiar with both the techniques and the equipment needed for the climbing assignment to avoid confusion or uncertainty while in the tree. New climbers shall be teamed with experienced climbers who can offer advice and monitor climbing technique and equipment use. Terminology must be understood by everyone involved.

4.1 Safety Equipment

The climbing assignment dictates the type of equipment required. Collecting material or cones from a young seed orchard requires far less gear than working in trees in the field. But every climbing assignment requires basic safety equipment: harness, lanyards, helmet, carabiners, suitable rope, and slings (safety straps).

4.1.1 Safety Harness and Climbing Belts

Always wear a properly constructed safety harness designed for rescue and rappel or a saddle belt and chest harness. The harness is a prudent safety precaution and makes rescue easier if something goes wrong while you are in the tree. One- or two-piece harnesses are suitable if they support the chest and pelvic areas. Remember, when climbing with spurs or when using Swiss Tree Grippers, *always wear your climbing belt over your safety harness, not instead of it.* Whenever climbing with spurs, a safety harness is acceptable if it has an integral climbing belt with suitable D-rings. Climbing belts by themselves do not provide suitable fall protection.

4.1.1.1 General Care

1. The following procedure is recommended when checking climbing belts and safety harnesses for broken or rotten stitching, cuts and cracks, loose or broken rivets, and excessive wear.
 - A. Using your hands, firmly fold the pliable material and check for defects on the top of the fold.
 - B. Roll the fold along the pliable material and continue checking until one side has been completed.
 - C. Repeat the process on the other side of the climbing belt or safety harness.
 - D. During this process, carefully check all other parts of the climbing belt or safety harness for defects.
2. Do not store safety harnesses and climbing belts with sharp or pointed objects; near heat, chemicals (especially gasoline), chemical vapors, or sunlight; or where the belt or harness may get wet.

4.1.2 Lanyards

Lanyards are adjustable lengths of rope or webbing that secure the climber to the tree, freeing the hands. While in a work position in a tree or when stopping to do anything with your hands, pass a lanyard around the tree bole or appropriate limb and attach both ends firmly to your climbing belt or safety harness. The one exception to this rule is when you are working from an approved rappel system. Always use lanyards that can be easily adjusted while climbing. Practice adjusting them while still on the ground. Before ascending a tree, master throwing and catching the lanyard around the bole as well as limb-over procedures (see section 4.1.2.4). Always use the correct type and length of lanyard for the job.

Carefully inspect hardware for secure closure before placing your weight on the lanyard. Make sure the snap catch is compatible with the D-rings on your belt or harness. Check for compatibility by attaching the snap catch to the D-ring, then twisting the snap catch against the D-ring to see if the snap-catch closure can be opened. If the snap catch is too large for the D-ring, it can be opened in this manner, causing failure.

Many types of mechanical adjusters can be used as an alternative to the Prusik system, making the rigging and adjustment of lanyards much simpler.

4.1.2.1 Types of Lanyards

Many types and styles of lanyards are suitable for tree climbing work. These can be divided into three categories:

1. *Belt lanyards or lineman's safety straps.* Belt lanyards normally consist of a wide piece of nylon webbing with an adjustable buckle and a snap catch at both ends. Generally, these are not the best choice for tree climbing because they are awkward to adjust and come in just a few sizes.
2. *Prusik lanyards.* Prusik lanyards are equipped with a snap catch at both ends and are adjusted by means of either a Prusik knot or a metal friction adjuster. The lanyards come in a variety of sizes and styles that meet almost every climber's needs. Some styles may be awkward to adjust, but most adjust quickly and easily. The versatility of this lanyard has made it the preferred "all purpose" lanyard for tree climbing. Never use these lanyards for primary support when cutting, trimming, or pruning trees because of the possibility that the lanyard might be cut (see paragraph 4B below).

4. Climbing Safety—Equipment, Systems, and Procedures

3. **Mechanical adjuster lanyards.** Mechanical adjuster lanyards come with a snap catch at one end and a mechanical adjuster that can be moved along the lanyard and attached to the climber's belt or harness. These rope or cable steel-core lanyards are the easiest to adjust as the adjustment takes place at the climber's waist. Safety measures include placing an end splice or knot at the end of the rope to prevent the adjuster from going off the end and keeping the adjuster cam cleared of twigs and leaves.
4. **Steel-cable or cable-core lanyards.** These lanyards are typically made from bare steel cable or from cable core manila or nylon rope and are considered cut-resistant.
 - A. Steel-cable lanyards (no rope sheath around cable) recommended for tree climbing work include those that come with the Swiss Tree Gripper set and those used as a backup lanyard when climbers are using a chain saw or other cutting tool.
 - B. Cut-resistant lanyards shall meet the minimum breaking strength of 5,400 pounds. Use cut-resistant lanyards when spur climbing or when cutting, trimming, or pruning in trees.

Lanyards made from cable core manila or nylon rope have an eye spliced at one end of the rope that contains a snap catch. Always inspect the steel-cable core before use to ensure that the cable passes around the eye splice and is spliced or crimped back onto itself. The lanyard is snapped into a D-ring on one side of the climbing belt or safety harness and fastened to a D-ring on the opposite side with a Becket hitch or a mechanical lanyard adjuster. When using the lanyard for support, always maintain at least an 18-inch tail on the running end where the Becket hitch is tied. For normal climbing, these lanyards should be at least 15-feet long. Longer lanyards are needed for climbing very large trees.
2. A Prusik lanyard similar to the 4-inch tie-in system described in sections 4.2.2.1 and 4.2.2.2 can be easily adjusted at any time because the adjuster knot is always within reach.
 - A. To shorten the lanyard, simply grasp the rope behind the Prusik knot and rotate your hips, pulling the lanyard around the tree to the same side of the tree as the Prusik knot. Then, while counterrotating your hips, push the Prusik knot along the lanyard rope toward the tree.
 - B. To lengthen the lanyard, simply pull the Prusik knot and slide it along the lanyard rope toward you.
3. When a steel-core manila rope lanyard or a steel-core nylon rope lanyard is used with a Becket hitch, adjust the lanyard as follows:
 - A. With both ends of the lanyard attached to a climbing belt or safety harness, rotate your hips and pull the lanyard around the tree bole toward the side containing the Becket hitch.
 - B. Reach across the front of your body from the side where the lanyard is snapped and grasp the lanyard near the tree bole between the bole and the D-ring where the Becket hitch is tied. Pull your body forward, rotating your hips back to their normal position to remove pressure from the Becket hitch.
 - C. With your free hand, adjust the Becket hitch to lengthen or shorten the standing part of the lanyard.
 - D. Check the Becket hitch. Make sure it is properly positioned and secured on the D-ring before placing your weight back on the lanyard.
4. When a mechanical adjuster is used, taking up or letting out slack is much easier and safer.
 - A. Rotate your hips slightly toward the side that the adjuster attaches to the D-ring of the climbing saddle, belt, or harness, and pull the lanyard through the adjuster toward your body. Make sure the spring-loaded cam retracts to "bite" the rope before placing your weight back on the lanyard.
 - B. To lengthen the lanyard, gently depress the cam and either pull the lanyard through the adjuster away from your body or rotate your hips away from the adjuster. Check the cam for security before placing your weight back on the lanyard.

4.1.2.2 Lanyard Adjustment

Adjusting a lanyard that is supporting your weight can be awkward, depending on the type of lanyard.

1. Belt lanyards, and some Prusik lanyards that adjust by means of doubling back on themselves, can be awkward because the adjusting mechanism may be behind the tree. This should be planned for, and precautions should be taken to prevent this from being a problem.

4.1.2.3 Lanyard Throwing and Catching

Passing the lanyard around the tree must be done many times throughout a climbing assignment. It is not a difficult task on small-diameter trees where you can reach completely around the bole, but on larger trees, the end o

the lanyard must be thrown around the bole and caught on the opposite side. This maneuver is sometimes complicated by tree limbs and the need to change points of contact. When throwing and catching a lanyard around the bole:

1. Establish a stable position with three points of contact (three-point climbing system).
2. Whenever possible, throw the lanyard with your dominant hand and catch it with your other hand. This may not always be possible, such as when limbing over during spur climbing. It is also advisable to throw the end that has the least amount of hardware or lanyard material (such as the end that does not contain the adjusting mechanism) to avoid snagging the lanyard on tree limbs.
3. Grasp the lanyard 1 to 1½ feet from the snap end. The farther the lanyard is held from the snap end, the less control you will have during the throwing maneuver.
4. Note the location of limbs around the tree bole and the area where the snap end will be thrown and caught.
5. With a slightly bent arm, throw the snap end around the tree with a sweeping, horizontal arm motion. As the snap end begins to pass around the tree, allow the lanyard to slip through your throwing hand to add length to the lanyard being passed around the tree. Judgment and experience are needed to determine how much of the lanyard to let slip through your throwing hand.
6. Allow just enough of the lanyard to slip through your throwing hand so that the snap end will not hit you when it comes around the tree. It is safer to trap the snap end against the bole after it strikes the tree than to attempt to catch the thrown end directly.
7. Once you have caught the snap end, secure the snap to the safety harness. Check both ends of the lanyard to make sure they are securely fastened before putting your weight onto the lanyard.
8. When placing the lanyard during the climb for the first time, you may have to release one of your handholds to catch the end of the lanyard. You can maintain three points of contact by wrapping your throwing hand around the bole to support your upper body or by keeping your throwing arm over a live limb capable of supporting your weight. Remember, when you throw the first lanyard the first time you may reduce the number of points of contact, putting you temporarily in a potentially hazardous position. Hanging the snap end over a limb and reaching around is one way to maintain contact with the tree.

4.1.2.4 Limb-Over Technique

When climbing with spurs, Swiss Tree Grippers, or when ascending unsecured sectional ladders, you must often pass one or more live limbs while keeping a lanyard around the tree or suitable branch for support. To pass the limbs safely, you need to perform a limb-over maneuver:

1. The limb-over maneuver requires you to pass a second lanyard around the tree above the limb or limbs being passed. Fasten the second lanyard to your climbing belt or safety harness. Make sure the second lanyard is properly adjusted for length and properly fastened to your belt or harness before releasing the first (lower) lanyard.
2. Use two different types of lanyards or lanyards of different colors if you anticipate having to perform limb-overs. This ensures that you can tell them apart during the maneuver. Make sure the lanyards are long enough to allow ready adjustment during long limb-over reaches.
3. Transferring your weight to the upper lanyard makes it easier to release the lower lanyard.
4. The limb-over maneuver is also performed during a descent by reversing the procedure. The limb-over descent technique requires you to pass a second lanyard around the tree below the limb or limbs being passed. Again, make sure the second lanyard is properly fastened to your climbing belt or safety harness and adjusted before releasing the upper lanyard.

4.1.2.5 Care of Lanyards

1. Fiber and synthetic lanyards
 - A. For material other than rope, use the inspection procedures outlined in section 4.1.1.
 - B. Check knots, splices, and metal parts for defects.
 - C. Inspect rope lanyards and retire them when the rope meets the criteria described in section 3.1.6.
 - D. Never store lanyards with sharp or pointed objects.
2. Steel-core rope lanyards
 - A. Remove sharp edges and protruding cable.
 - B. Check for weaknesses in the steel core.
 - C. Inspect the cable splice for defects.
3. Steel cable lanyards (when used with the Swiss Tree Grippers only)
 - A. Inspect for kinks, knots, and fraying.

4.1.3 Carabiners and Screw Links

Carabiners are considered safety equipment because they are a strong and secure means of attachment. Using carabiners instead of knots can save time and energy and avoid the mistake of tying a knot incorrectly or using an improper knot.

Carabiners come in a variety of shapes and sizes, such as oval, D-shape, modified D-shape, or offset (figure 4a). Carabiners can be used for attaching equipment to the haul line, joining two ropes, attaching equipment to the safety harness, reducing line abrasion, and various other applications.

Carabiners can be used for years if they are not damaged by a serious blow or long fall (hairline fractures can develop in aluminum carabiners after a fall). Inspect all carabiners frequently.

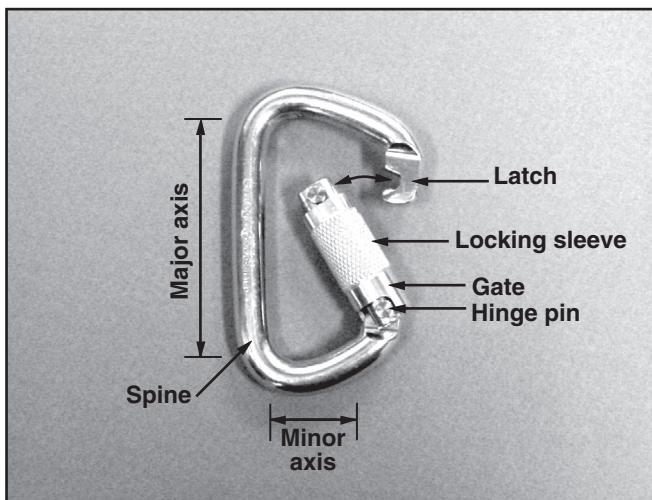

Figure 4a—Carabiner.

Carabiners used in tree climbing for life-support applications shall be the self-closing, positive-locking type with a minimum tensile strength of 5,000 pounds or 22kN. Several types of steel and aluminum carabiners meet this requirement.

Steel carabiners are heavier than aluminum carabiners and will usually have a greater breaking strength. While the extra weight can be a disadvantage when carrying equipment into the tree, the steel carabiner is stronger. Steel carabiners handle impact better than aluminum ones and will allow a rope to slide with less friction.

A carabiner with a large gate opening is needed for use with a Sky Genie and is recommended for any rescue situation. Carabiners shall not be painted or covered with tape (other than a small piece for identification) because the covering may mask fractures or other defects.

Carabiners can be used for years if they are not damaged by a serious blow or long fall (hairline fractures can develop in aluminum carabiners after a fall). Inspect all carabiners frequently.

Carry plenty of carabiners into the tree or have them available on the ground. When attaching a carabiner, always make sure it is properly attached, it is loaded only through the long axis, and its gate is closed and locked. **Never place a load on the gate of a carabiner.** Screwlock carabiners can be used only in applications that do not involve life support. When using these carabiners, don't overtighten the locking mechanism or tighten it when the carabiner is under load; doing so may cause the locking mechanism to jam.

To loosen a stubborn locking mechanism, apply tension along the carabiner's long axis while turning the locking mechanism. If you must use pliers, avoid damaging the locking mechanism.

Like carabiners, screw links are a strong, secure means of attachment and can be used instead of knots. They have a threaded sleeve closure instead of a spring-loaded hinged gate (figure 4b). Screw links can withstand multidirectional forces placed on them while carabiners are only designed to be loaded along their long axis. Consider using screw links when a semipermanent attachment is needed (such as chicken loops) or to attach tie-in points on a chest or seat harness. Do not overtighten the gate screw. When screw links have been under a heavy load, you often need pliers to loosen the threaded sleeve.

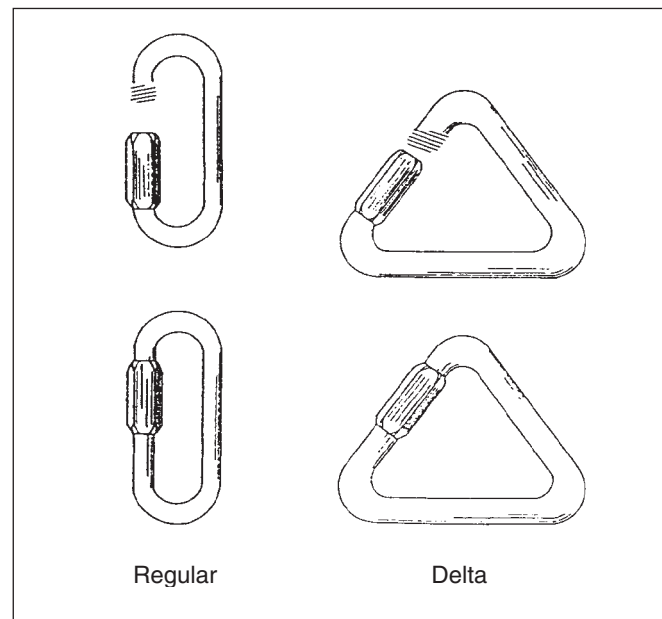

Figure 4b—Screw links.

To clean carabiners and screw links, use compressed air to remove grit and use hand cleaner to remove sap. Thoroughly rinse and dry. Use graphite to lubricate components. Never use oil because it will attract dust and harm the rope.

4.1.4 Helmets

Helmets shall be used on all climbing assignments by both the climbers and the ground persons. All helmets shall be certified as meeting the requirements of the UIAA (Union Internationale des Associations d'Alpinisme). These helmets have been tested for multidirectional impact and puncture resistance, shock absorption, and the ability to remain on the head on impact. It is critical that the three-point chinstrap be worn at all times when climbing. Helmets meeting ANSI (American National Standards Institute) Standard Z89.1, Type II, which are equipped with a 3-point harness, are also acceptable. Standard hardhats are not authorized for tree climbing.

4.1.5 Slings (Safety Straps)

Safety straps may be constructed from rope or webbing (by knotting) or bought commercially. They are generally used as protection or anchor points in the 4-inch tie-in system or during a belayed ascent. Where added protection is necessary (as when climbing above the 4-inch-bole-diameter level), place protection at least every 3 feet along the bole.

To construct a sling:

1. Prepare a length of rope or webbing that is long enough to accommodate the tree diameter, plus about one additional foot. The length will depend on the type of material used and the manner of sling construction. Material meeting the 5,400-pound breaking strength requirement may have a loop formed in each end. Material that does not meet the breaking strength requirement must be constructed in a manner that will provide a minimum 5,400-pound breaking strength for the sling.
2. When the ends of the rope or webbing have been prepared to prevent unraveling, either tie a figure-8 bend or a water knot to join the two ends into a continuous loop, or tie a figure eight on a bight at each end to form loops at both ends.

To use a sling:

1. Pass the sling around the tree bole and secure both ends of the sling with a single carabiner. Don't use a girth hitch to secure a sling around a bole (see figure 4e). This practice creates potentially dangerous stress on the sling.

2. Run the safety line through the same carabiner used to attach the sling to the tree. Never pass the safety line between the bole and your sling.

4.2 Safety Systems

4.2.1 Three-Point Climbing System

The three-point climbing system incorporates the basic principles used at all times when tree climbing. The only exceptions to using the three-point system are when rappelling from a tree using an approved rappel system or when using an approved ascender system.

While climbing, each hand and foot is considered a potential point of contact (other parts of the body, such as a hooked knee or armpit, may be considered contact points if the point of contact is capable of supporting the full body weight). A lanyard around the tree bole or suitable branch that is secured to the safety harness or climbing belt on both ends counts as two points of contact. **While climbing, three points must be placed firmly in position on a secure surface before moving to another point.** The secure surface may be sound, live tree limbs that can support your weight, rungs on a ladder, positions on a safety line or lanyard, climbing spurs, pole steps, tree steps, ascenders, or Swiss Tree Grippers.

All three points must be secure before you move. When you learn and apply this basic rule, it becomes a matter of habit to safely climb using the three-point system.

Always place your hands and feet next to the bole on a sound limb. When a limb is less than 3 inches in diameter, wedge your foot into the bole at the base of the limb perpendicular to the limb. Never use a dead branch, branch stub, or unsound live branch for support. Saw or break off dead branches, branch stubs, and unsafe live branches to eliminate the possibility of using these as contact points. Never place both hands or both feet on a sound live branch less than 3 inches in diameter.

Support your weight as much as possible with the large leg muscles, or when using your hands, fully extend your arms to reduce upper-body fatigue. Keep your body as close to vertical and as close to the trunk as practical when free climbing. When you are in a work position and secured with a lanyard or rappel system, you may lean out to do the work. Free climbing is limited to that portion of the live crown below the 4-inch bole diameter. Above that level, use a safety line system for added protection.

4.2.2 Four-Inch Tie-In System

A 4-inch tie-in system is a belayed safety line system that is required when climbing and working above the 4-inch bole diameter level of the tree and may be either self-belayed or ground belayed (figure 4c). The belay systems allow the climber to work above the 4-inch bole diameter level in relative safety. Both self-belay and ground-belay rigging equipment is relatively inexpensive and easily replaced when worn or damaged, but the equipment may be time consuming to set up and take down. The self-belay system does not have to be operated by a ground person, freeing the ground person to assist the climber in other ways. Both belay systems can hinder the climbers' ability to descend quickly in an emergency.

Both belayed climbing systems have these requirements:

1. The systems shall be secured to the tree bole at or below the 4-inch-bole-diameter level of the tree (figure 4c)
2. Above the 4-inch bole diameter level, protection (a rigging point) is installed at least every 3 feet along the bole to limit falls to no more than 6 feet.

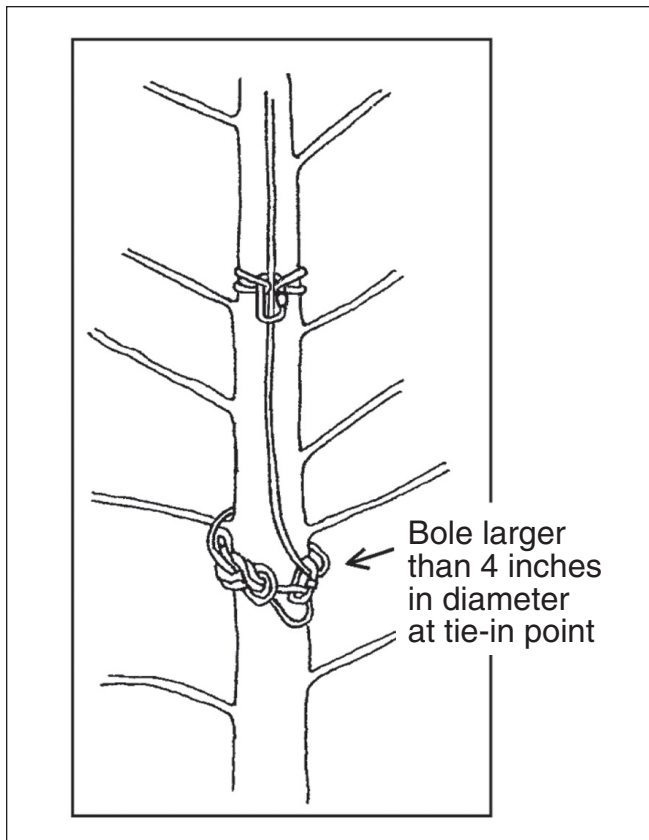

Figure 4c—Four-inch tie-in anchor system.

3. **The belay system shall have one end of the safety line secured to the tree or the belay anchor, with the other end secured to the climber AT ALL TIMES that the climber is at or above the 4-inch bole diameter level.**
4. Safety lines shall be constructed with dynamic rope. Static ropes and webbing are not suitable because they will cause dangerous stresses on the anchors and the climber in a fall.
5. Each part of the system shall be constructed of material that meets or exceeds the 5,400-pound breaking strength standard.
6. The system should be easy to set up and simple to operate.

The construction and operation of two belay systems are as follows:

4.2.2.1 Self-Belayed Two-Piece Prusik System

1. See figure 4d for construction details. A 30-foot length of rope allows the climber to go less than 30 feet above the tie-in point, depending on the type of protection used to secure the safety line and whether knots or eye splices are used.
 - A. Make an eye-splice loop or form a loop by tying a figure eight on a bight at BOTH ends of the rope.
 - B. Clip a locking carabiner to each of the loops.
 - C. Tie a Prusik knot around the safety line with a separate piece of rope that is formed into a continuous loop.
 - D. To construct a continuous loop for the Prusik, select an appropriate type and length of rope, then tie the ends together with a grapevine knot or a figure-8 bend. You will need a 5- to 6-foot length of rope. The continuous loop should be constructed from rope that is either the same diameter or slightly smaller than the safety line and just as stiff as the safety line or slightly softer. Softer rope is preferred for the Prusik to ensure a solid grab on the main rope in the event of a fall. Examples of suitable rope combinations include:

Continuous Loop	Safety Line
11-millimeter dynamic kernmantle	$\frac{7}{16}$ -inch hard lay
$\frac{5}{16}$ -inch kernmantle	$\frac{7}{16}$ -inch hard lay
10.5-millimeter kernmantle	11-millimeter kernmantle
$\frac{7}{16}$ -inch soft lay	$\frac{7}{16}$ -inch hard lay

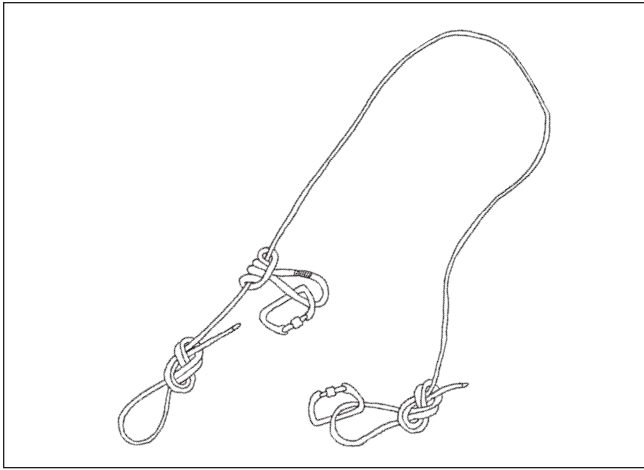

Figure 4d—Two-piece Prusik system.

These are just a few examples of rope combinations that can be used. Test different rope combinations before actual use. You may need to check with the manufacturer to ensure compatibility. On some ropes, the Prusik knot will not hold adequately, while on others the knot will bind too tightly.

- E. Run the rope through the Prusik knot until the knot grabs when under tension.

2. Instructions for use.

- A. Place a lanyard around the tree and secure it to the climbing harness.
- B. To tie in at or below the 4-inch-bole-diameter level, either wrap one of the eye-spliced ends of the rope around the bole and clip the carabiner back to the rope or directly tie into the tree using a figure eight on a bight (which reduces the amount of equipment needed). Lock and check the carabiner.
- C. Fasten the carabiner on the other eye-spliced loop to the attachment point(s) of the safety harness. Lock and check the carabiner.
- D. Tie the Prusik knot continuous loop near the tie-in point around the tree.
- E. Attach the continuous loop to the attachment point(s) of the climbing harness with a carabiner(s). Use lanyard D-rings if they are integral to the full-body support of the safety harness, but not if they are designed for support by the waist belt only. If you are using the lanyard D-rings, the attachment must be to matching D-rings on BOTH sides of the harness. Attach one carabiner to each D-ring. Lock and check the carabiners.

- F. Unfasten the lanyard and climb up the tree, sliding the Prusik knot up with you.
- G. At 3-foot intervals, place protection around the tree bole and clip the protection to the rope. Remember to secure yourself to the tree bole with a lanyard each time you stop to set a protection point. Protection is provided by:

- Wrapping a sling (figure 4e) around the bole above a branch whorl and using a carabiner to attach it to the safety line below the Prusik knot. Allow sufficient slack in the sling to prevent load from being applied to the side of the carabiner. The safety line should run through the carabiner, NOT between the tree and the sling.

OR

- Clip a carabiner to the safety line below the Prusik knot, pass the carabiner and the attached portion of the safety line around the bole above a branch whorl, and clip the carabiner back onto the safety line.

CAUTION: This method will result in continuous exposure to the climber and has a fall factor greater than 1.0.

Always lock and check carabiners.

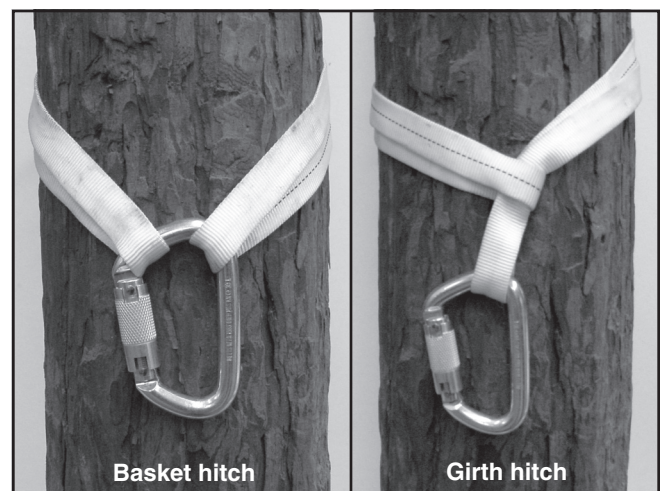

Figure 4e—A sling wrapped around a bole.

NOTE: A girth hitch will reduce sling strength. For climbing applications where a sling provides an artificial foot-hold, and for climbing line redirects where potential fall factors are low, the use of a girth hitch is acceptable. Use the basket hitch for life support anchors and protection points in ground-belayed and self-belayed climbing applications where the climber may be above the highest installed protection point.

4.2.2.2 Ground-Belayed System

1. Refer to section 4.2.3 for setup instructions.
 - A. This system requires the ground person to belay the climber from a secure anchor point on the ground.
 - B. Set up a belay anchor near the tree to be climbed and rehearse procedures and signals with the ground person before ascending.
 - C. The safety line should be long enough to reach from the anchor point to the top of the tree with 50 feet to spare (as a margin of safety). Tie a figure-8 knot at the tail end of the safety line to prevent the belay rope from slipping out of the belay device (in case you underestimate the length of rope needed for the climb).
2. Instructions for use.
 - A. Tie a figure eight on a bight at the leading end of the safety line and use carabiners to attach the safety line to the attachment point of the climbing harness. Use lanyard D-rings if they are integral to the full-body support of the safety harness, but not if they are designed for support by the waist belt only. If you use the lanyard D-rings, the attachment must be to matching D-rings on BOTH sides of the harness. Lock and check the carabiners.
 - B. Begin the ascent. Place protection periodically, spaced with regard to the belay anchor, climbing difficulty, and hazards. Above the 4-inch-bole-diameter level, place protection points at 3-foot intervals. Climbers should be aware that in the event of a fall, they will fall from the point of their release, past the last protection point, to a point that is below the protection point. For example, if you are 6 feet above the last protection point, you will fall at least 12 feet (plus whatever slack exists in the rope) before the rope can arrest your fall. The closer together your protection points are, the shorter the fall.
 - C. Protect the climber by wrapping a sling (safety strap) around the bole above a branch whorl and attaching the sling to the safety line with a carabiner. Allow sufficient slack in the sling to prevent load from being applied to the side of the carabiner. **The safety line should run through the carabiner, not between the tree and the sling.**

- D. Added protection can be gained by installing a sling above the climber's head and attaching the safety line to the sling before the ascent begins. The climber is continually on a taut safety line and is constantly secure from even a short fall. This method is slow and tiring, so use it only for difficult moves in the tree.

4.2.2.3 Care and Cleaning of 4-Inch Tie-In Systems

Refer to sections 3.1.4 and 3.5.4 for care and cleaning instructions for rope and webbing.

1. Inspect the safety line for signs of wear or excessive pitch. If pitch cannot be removed, replace the safety line. If the safety line shows signs of excessive wear as described in section 3.1.6, replace it immediately.
2. Inspect slings (safety straps) for signs of wear. Replace them immediately if the straps show signs of excessive wear.
3. Inspect the friction side of Prusik knots for signs of excessive wear. Replace continuous loops or shorten the safety line to remove the worn sections.

4.2.3 Belayed Climbing System

If set up and operated properly, a belayed climbing system can protect the climber throughout the climb (figure 4f). A belay is simply a means of securing a person with a rope to keep accidental falls short and reduce the risk of injury. The elements for a belayed climbing system are the same as for the 4-inch tie-in system (a self-belayed system), except the anchor is provided by the ground person and is continuously adjusted as the climber moves. A belayed climber can use the same system for the entire ascent, including ascent above the 4-inch bole diameter (see section 4.2.2.2). The belay rope must be a dynamic rope to protect the climber in the event of a fall. It is important to remember that any belay is a backup safety-system used to reduce the risk of serious injury or death from an accidental fall. A climber who falls in a tree is likely to receive significant injuries when striking limbs, stobs, and equipment. When climbing, always use the three-point climbing system and never rely on any belay system as a primary support while in the tree.

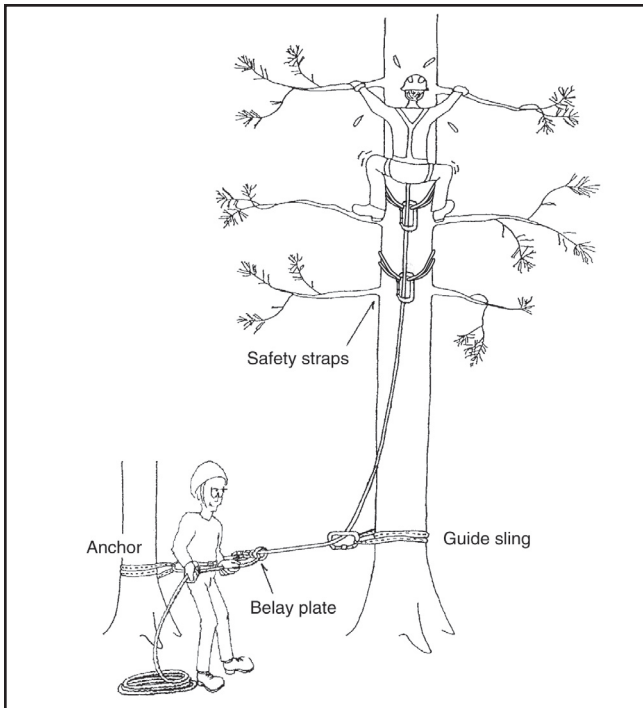

Figure 4f—Belayed climbing system.

4.2.3.1. Anchors

To set up the belayed climbing system, the climbing team must discuss the route of ascent and determine the best location for the belay anchor point.

1. The anchor point shall be located away from the tree being climbed because the belayer's movement is extremely limited. The belayer needs to be safe from falling objects and must be able to see the climber at all times.
2. A belay anchor point can be established by securing a sling around a suitable tree bole above any extreme butt swell. The anchor point is set low to prevent the belay device from being pulled out of the belayer's reach during a fall. Figure 4e illustrates methods of securing a sling. The anchor material must meet the 5,400-pound breaking strength requirement and should NOT be configured into a girth hitch, which could create dangerous stresses (figure 4g) on the sling.
3. To be used as an anchor, a tree bole must be at least 12 inches in diameter and free of rot. If an adequate single point is not available, multiple smaller points set up with a self-equalizing anchor system should be used.
4. After the belay anchor and belay device are rigged, attach the belayer to the anchor point with a separate carabiner that is attached to the attachment point(s) of the safety harness. This ensures that the belayer will

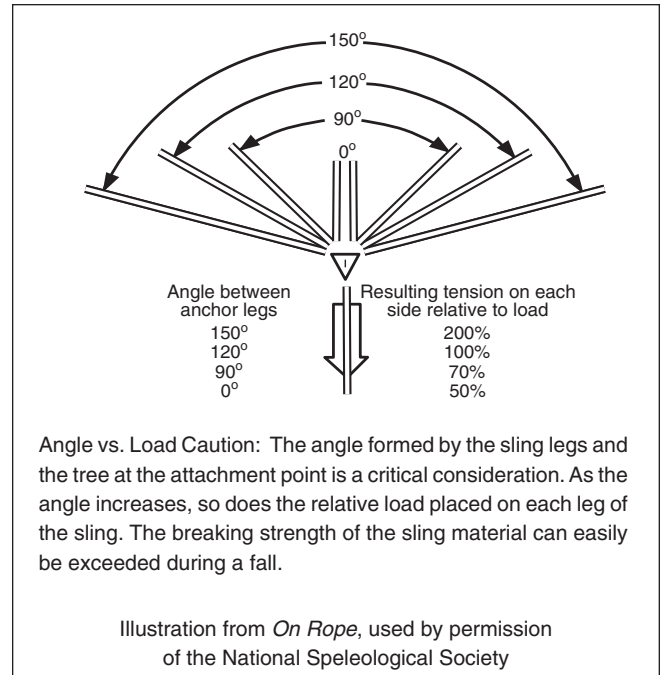

Figure 4g—The angle formed by the sling legs and the tree is critical.

be within reach of the belay device in the event of a fall, which could cause the belay rope to slide up the tree. (This step can be delayed until the rest of the system has been set up.)

5. To control the direction from which the falling forces will affect the anchor and belayer, establish the first protection point close to the ground on the tree being climbed.
6. The belayer should have a Prusik loop or ascender that can be applied with one hand, so the belay can be secured after a fall or other problem. This also allows the belayer to escape the belay while keeping the climber secured.

4.2.3.2 Belay Devices

Once you have established a belay anchor point, clip a large carabiner into the anchor sling. Next decide which technique to use for the belay. A number of belaying techniques exist, but they all work essentially the same way: A belay creates a braking action on the rope to prevent the person at the end of the rope from falling far enough to cause injury. Belays that may be used for tree climbing work include the M \ddot{u} nter hitch belay and the belay-plate belay. **NEVER USE A BODY BELAY** because this technique can injure the belayer and the climber.

4. Climbing Safety—Equipment, Systems, and Procedures

1. *Münter hitch belay.* This system does not require any additional equipment other than the anchor sling and a large locking carabiner. It is an inexpensive system that is simple to set up and use correctly.

- A. Attach a large locking carabiner to the anchor sling. Using a Münter hitch (figure 4h), attach the belay line to the locking carabiner. Lock and check the carabiner gate.

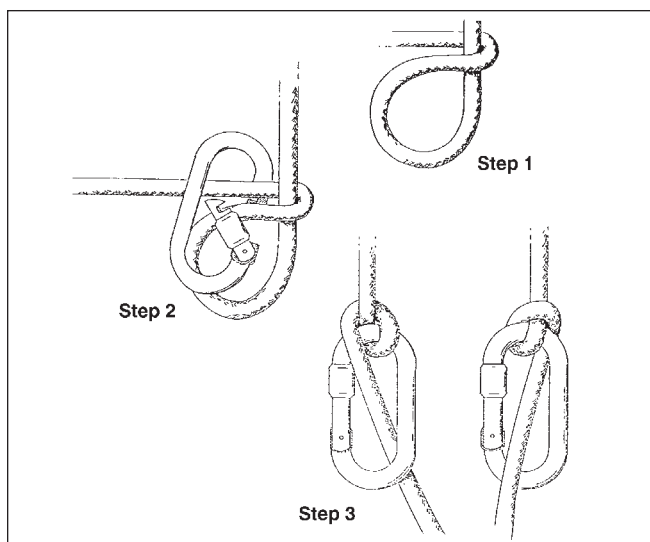

Figure 4h—Münter hitch.

- B. Attach the belay rope to the climber's safety harness. The climber is ready to begin the ascent. Establish the first protection point (safety strap) close to the ground on the tree being climbed; this controls the direction from which a fall will affect the anchor and belayer. The climber places safety straps at intervals along the bole. Remember, the distance of a fall at any point will be at least twice as far as the distance between the climber and the last protection point, plus any slack in the rope.
- C. The belayer must hold the rope firmly with the brake hand to arrest the climber's descent in the event of a fall. The belayer must visualize the direction of the forces that a fall would generate to select a secure belay position. The belayer must be able to absorb the shock of a fall from this position. If enough rope is available, the belayer can lower the climber to the ground by releasing pressure on the brake hand. (**NOTE:** A 164-foot [50-meter] climbing rope allows the climber to be lowered to the ground from only about 75 feet [some of the rope length is taken up by knots]).

2. *Belay-plate belay.* The belay-plate belay system requires a manufactured belay plate (figure 4i). Belay plates come in a variety of sizes and shapes. They are generally designed for use with a specific range of rope diameters and flexibility. Some figure-8 descenders are designed with a belay plate in either the small ring or between the small and the large rings. Follow the manufacturer's instructions when using figure eights for belaying. Some figure eights are not designed for belay use and others are used differently. Figure eights either do not provide sufficient friction or do not feed freely enough for use as a belay device when rigged in a rappel configuration. Belay plates should only be used with kernmantle rope. The tendency of laid ropes to twist and form kinks makes them unsuitable for use with belay plates. To set up and use the system:

- A. Make a bight in the rope near the end of the belay rope that will be attached to the climber's safety harness.
- B. Push a few inches of the bight through the hole in the belay plate and clip the anchor point carabiner onto the bight so that the belay plate is secured to the rope. Some belay plates are designed to face in only one direction (see manufacturer's directions).
- C. Secure the optional keeper loop by clipping a carabiner through it, directly into the anchor point sling. The keeper loop is a loop of small-diameter cordage, about 8 inches long, which is attached through a small hole in the belay plate. When secured in place, this piece of cordage keeps the belay plate from sliding down the rope and out of the belayer's reach (not normally a problem if the belayer is attentive and belaying correctly).

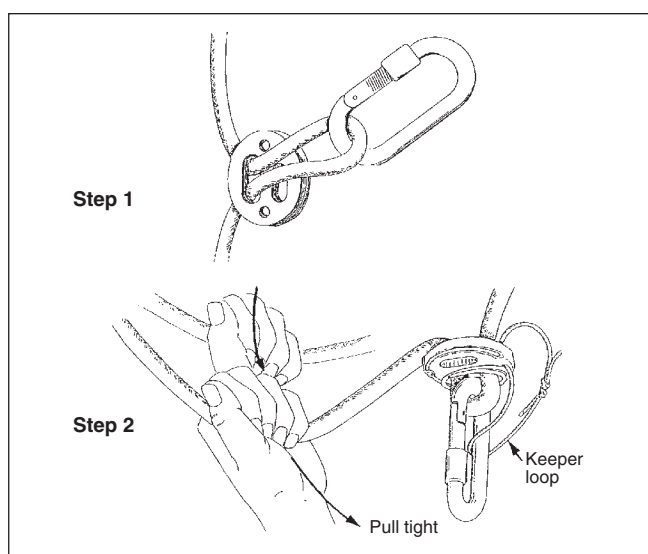

Figure 4i—Using a belay plate.

- D. Attach the belay rope to the climber's safety harness. Establish the first protection point (safety strap) close to the ground on the tree being climbed; this protection point controls the direction from which a fall will affect the anchor and belayer. The climber should weave in and out of the branches or place safety straps at intervals along the bole for the system to work properly. The distance of a fall at any point will be at least twice as far as the distance between the climber and the last protection point, plus any slack in the rope.
 - E. In the event of a fall, the belayer initiates braking by spreading the angle of the rope strands apart to 180 degrees and holding the rope firmly in the brake hand. If enough rope is available, the belayer can lower the climber to the ground by releasing pressure on the brake hand.
- 2. The dominant hand grasps the rope on the side of the belay device opposite the climber. This is the brake hand. **THE BRAKE HAND MUST NEVER BE TAKEN OFF THE ROPE WHEN A PERSON IS ON BELAY.** The weaker hand (left hand for right-handed person) grasps the rope leading directly to the climber. This is the guide hand, which helps manipulate the belay rope.
 - 3. Before the climber leaves the ground, the belayer's harness is secured to the attachment point of the belay device. This prevents the force of a fall from pulling the device away from the belayer, which would cause the belay system to fail. The belayer wears gloves to prevent rope burns.
 - 4. The brake hand and guide hand must work together for a smooth belay. When the climber is ascending, the guide hand works to pull the belay rope out of the belay device while allowing the climber to set the rate of rope run. The brake hand grasps the belay rope firmly, and as the brake hand approaches within a foot of the carabiner, the belayer slides it back away from the carabiner **while still holding the rope.** When the climber is descending, the guide hand and brake hand remain in the same positions, but motions to feed the rope through the belay device are reversed. **NEVER TAKE THE BRAKE HAND OFF THE ROPE.**
 - 5. It is critical that the belayer maintain the proper amount of slack in the belay rope. If the rope is too taut, it can interfere with the climber's balance and mobility. There should be at least some visible slack in the rope, but excessive slack will increase the length of a fall or could cause the rope to hang up.
 - 6. The belayer must watch the climber at all times until the climber signals "Off belay." The belayer must not become distracted for even a second because that may be the instant the climber falls. Any delay in initiating the braking action can result in injury to the climber or the inability to completely arrest the fall.
 - 7. The belayer must be in constant communication with the climber. Both must speak loudly and clearly to avoid confusion. Each instruction from the climber must be acknowledged with an appropriate response.
 - 8. A fall or other emergency may require the belayer to tie off the belay and leave the belay stance to assist the climber. The belayer may be pulled away from the belay stance or even off the ground by the force of a fall. For this reason, **BELAYERS MUST HAVE EQUIPMENT ON THEIR PERSON AT ALL TIMES THAT ALLOWS THEM TO SECURE THE BELAY,** if necessary. This equipment includes several carabiners and a Prusik loop or ascender that can be mounted on the rope with one hand.

4.2.3.3 Climber's Responsibilities and Procedures

- 1. Attach the end of the belay rope to the climber's safety harness in accordance with the manufacturer's instructions. The tie-in point should be at or above the waist to keep the climber upright in the event of a fall. If the tie-in point is a chest harness, the chest harness must be securely linked to the seat harness with a connecting strap so that the force of a fall is absorbed through the seat harness. **Never tie in to a chest harness without the connecting strap.** (A fall could result in extensive back and abdominal injuries.) Passing the belay rope through the chest harness carabiner to an attachment point on the seat harness is another acceptable way of attaching the belay rope to the climber.
- 2. Place safety straps as needed or at 3-foot intervals, as required, above the 4-inch-bole-diameter level of the tree.
- 3. The climber must be in constant communication with the belayer. Both must speak loudly and clearly to avoid confusion. Remember, the belayer is in control of the climber's safety and needs clear, concise directions to provide the necessary support.
- 4. The climber must be secured to the tree bole with a lanyard before signaling "Off belay."

4.2.3.4 Belayer's Responsibilities and Procedures

- 1. A right-handed belayer stands to the left of the device, slightly behind the carabiner where the M \ddot{u} nter hitch or belay plate is attached and facing the climber. A left-handed belayer would stand to the right of the device. (In either case, the dominant hand is farthest from the climber.)

4. Climbing Safety—Equipment, Systems, and Procedures

4.2.3.5 Communication and Working as a Team

Both climber and belayer should rehearse a sequence of signals, commands, and reactions for a smooth, safe climb. Climbers and belayers must know and use the standard belay voice signals. These signals, in sequence, are:

Climber	Belayer	Meaning
“On belay”		I am about to climb. Are you ready to arrest my fall?
	“Belay on”	I am ready to arrest your fall.
“Climbing”		I am starting to climb.
	“Climb”	Go ahead.

Once a climber is at a location where a belay is no longer needed:

Climber	Belayer	Meaning
“Off belay”		I am in a secure place and no longer need a belay.
	“Belay off”	I am no longer belaying you.

Some additional signals can assist communication between the climber and belayer. None of these signals requires a verbal response from the belayer, only the action asked for by the climber.

Climber	Belayer	Meaning
“Slack”		There is too much tension on the rope, feed me some rope.
“Take in”		There is too much slack in the rope. Belayer needs to take some rope away from the climber.
“Tension!”		Take up all slack and hold the rope tightly until I signal differently.
“Falling!”		I am falling. Prepare to receive my full weight.

In the event that the belayer has problems and cannot maintain the belay:

Climber	Belayer	Meaning
	“Secure”	I cannot maintain the belay. Secure a lanyard around the tree and attach the lanyard to the safety harness.
“Secured”		I have secured a lanyard and am in a safe position.

If a belay is lost, the belayer should reestablish the belay or secure the belay rope to a firm anchor as quickly as possible. The climber and belayer should discuss the situation and take appropriate action. Appropriate action may include terminating the climb.

4.3 Safety Procedures

4.3.1 Free Climbing in the Live Crown

Free climbing, as used in tree climbing, refers to climbing without the added security of a safety line. Free climbing may be done in the live crown of coniferous trees that have branches strong enough to support the climber’s weight. Free climbing is limited to the area below the 4-inch-bole-diameter level and should not be done in trees with steeply downsloping branches. When free climbing in the live crown you should do the following:

1. Use the three-point climbing system.
2. Place your feet and hands on branches as close to the bole as possible. When the limb diameter is less than 3 inches, wedge your foot into the bole at the base of the limb and keep it perpendicular to the supporting branch.
3. Never use a dead branch, branch stub, or unsound live branch for support. Remove unsafe branches, if possible, during the ascent to eliminate the possibility of using them.
4. Never place both hands or both feet on a sound, live branch less than 3 inches in diameter.
5. Keep your body close to vertical and close to the bole.
6. When suitable branches are far apart in the live crown and it is difficult to maintain three points of contact, consider using a lanyard around the tree, or suitable branch, or placing tree steps (see figure 5m) or etriers (see figure 4j) to aid in climbing. **NOTE:** When using etriers, attach them to the tree above a branch whorl with rope or webbing and attach the bottom of the etrier to the tree bole for secure placement. Always use a lanyard when using tree steps or etriers for support.
7. Whenever stopping to rest or perform any task, always secure yourself by placing a lanyard around the bole or a suitable branch.

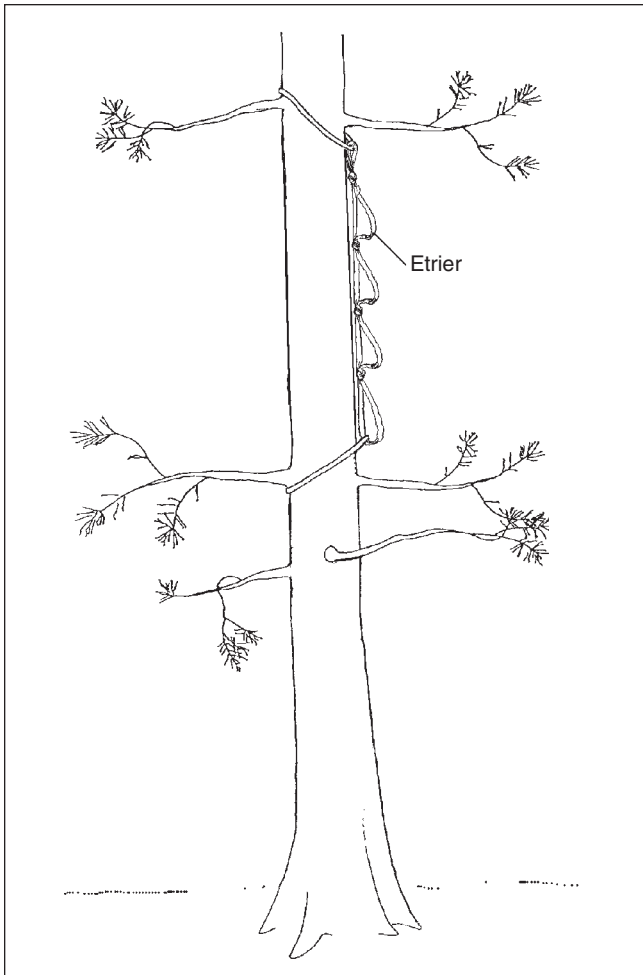

Figure 4j—Using an etrier.

4.3.2 Climbing and Working in the Live Crown With Support

Support may be provided by

1. a safety line secured to the tree below the 4-inch-bole-diameter level that is attached to you,
2. a safety line secured to you and attached to a secure anchor on the ground and belayed by a ground person,
3. a suitable rappel system such as the Sky Genie, Figure 8, rappel rack, or Prusik rappel system, or
4. a lanyard that is attached to your climbing harness and wrapped around the tree bole or suitable branch.

4.3.3 Climbing and Working in the Tree's Weak Areas

Always use a safety line when climbing and working above the 4-inch-bole-diameter level and in brittle, weak, or steeply sloping branches. Above the 4-inch-bole-diameter, use one of the 4-inch tie-in systems described in section 4.2.2 or the belayed climbing system described in section 4.2.3. When climbing and working above the 4-inch-bole-diameter level, keep your center of gravity close to the tree trunk and your back to the wind. Below the 4-inch bole diameter, when tree limbs are brittle, weak, or steeply sloping, use the belayed climbing system and place safety straps at 3-foot intervals, which will limit a fall to 6 feet.

4.3.4 Climbing and Working in Branches Away From the Tree Bole

This activity should be only done below the 4-inch-bole-diameter level where support systems are effective. Use either a long lanyard or a suitable rappel system for support.

4.4 Using Explosives in Trees

4.4.1 Determining Whether Explosives Are Needed

Before explosives are used in trees, it must be shown that their use is the safest and most economical way of completing the task. Explosives can be used to top trees for wildlife habitat, remove hazardous trees, and fell snags.

4.4.2 Climber Qualifications

The climber shall be a certified climber and a certified blaster.

4.4.3 Special Considerations

Wildlife specialists often remove treetops with explosives to mimic natural conditions more closely. The jagged, rough surface left after blasting is preferred by birds of prey looking for treetops where they will build a nest.

To ensure total breakage, the quantity of explosives required is based on the diameter of the tree (Forest Service Guide for Using, Storing, and Transporting Explosives and Blasting Materials: 2000 Edition [0067-2803-MTDC] available only to certified Forest Service blasters). More explosives are required if the charge is to be placed on the outside surface

4. Climbing Safety—Equipment, Systems, and Procedures

of a tree than if the explosives are placed in a hole drilled into a tree. Use water gel or emulsion-type explosives when topping trees. **Never use sensitive nitroglycerin-based explosives for this activity.** Use the following formula to determine the required quantity of explosives:

External charges: Pounds of water gel or emulsion-type explosives = $D^2/40$

Internal charges: Pounds of water gel or emulsion-type explosives = $D^2/250$

where D is the diameter of the tree in inches

When using an external charge where there is a thick layer of bark or an irregular surface, the blaster may opt to use a few more pounds than specified to ensure breakage. Remove thick layers of bark before placing explosives. Explosives should be packaged and placed to optimize the surface area where the explosive charge contacts the tree (this is known as coupling). External charges should be bundled or shaped in a cone or pyramid, with a detonator or detonating cord placed at the point and in the direction of the desired blast. When using an internal charge, be sure to drill the hole so explosives can be located across the center of the tree (at the center of mass).

Electric detonators shall not be used in trees. Nonelectric blasting caps (None), exploding bridgewire (EBW) detonators, or detonating cord may be used as initiating systems. Detonating cord that is spiraled down a tree trunk will leave a mark that simulates a lightning strike when detonated. Exercise caution when using detonating cord in dry conditions because the detonating cord could start a fire. As with all blasting operations, a minimum distance must be established to ensure that personnel are safe from flying debris. Typically, in blasting operations (such as when using fireline explosives) this distance is a minimum of 500 feet. In the case of tree topping, consider the possibility that the treetop could fall into a snag or series of trees. The blaster must select appropriate safety zones.

4.5 Using Chain Saws in Trees

4.5.1 Determining Whether a Chain Saw is Needed

In addition to the normal risks of personal injury from a chain saw, a climber has the risk of severing climbing lines or lanyards. Because of this danger, any use of chain saws in trees must be thoroughly justified and documented in the job hazard analysis. The work shall be done with the smallest saw that can do the job efficiently.

4.5.2 Chain Saw Endorsement Categories

1. Each of the following categories requires a separate endorsement (certification), in addition to the sawyer certification required by all categories.

EC-1. Cavity creation (including artificial cavities for red-cockaded woodpeckers or other cavity-nesting birds)

EC-2. Pruning and/or limbing in hardwoods (includes basic limb lowering)

EC-3. Pruning and/or limbing in conifers (includes basic limb lowering)

EC-4. Advanced rigging and heavy wood removal (topping/tree removal)

2. Specific endorsements are valid for 3 years, unless revoked earlier.

4.5.2.1 Prerequisites for Chain Saw Operators

1. Only those individuals certified as a Tree Climber or Tree Climbing Instructor will be eligible to obtain a chain saw endorsement.
2. Endorsement categories EC-1, EC-2, and EC-3 require a minimum “B” sawyer certification.
3. Endorsement category EC-4 requires:
 - a. As a minimum, certified as a “C” advanced sawyer.
 - b. Hazard tree assessment training.
 - c. Certification and recertification from a nationally recognized arborist organization [see FSH 6709.12-2001-2, Section 18.3(4)].

4.5.2.2 Prerequisites for Chain Saw Instructors

1. Instructors for all endorsement categories (EC-1, 2, 3, and 4) must hold a valid tree climbing instructor certificate as well as a valid “C” sawyer certificate.
2. In addition, to train individuals in endorsement category EC-4, instructors must obtain relevant training and certification from a nationally recognized arborist organization [see FSH 6709.12-2001-2, Section 18.3(4)].

4.5.3 Equipment

1. Chain saws shall be clean and in good operating condition with at least the following safety features: chain brake, chain catch, spark arrester, and throttle lockout. A low-kickback chain should be used.
2. The following personal protective equipment shall be worn while operating a chain saw in a tree.

- a. Eye protection.
- b. Hearing protection.
- c. Climbing helmet.
- d. Gloves.
- e. Boots made of heavy leather or other cut-resistant material.
- f. Leg protection—Because the leg straps of the standard Forest Service chain saw chaps could get hung on branch stubs while climbing, chain saw protective pants or protective inserts for the legs are acceptable alternatives. All chain saw protective garments shall meet the intent of Forest Service Specification 6170-4f.

4.5.4 Working in the Tree

Climbers shall adhere to the following safe work practices:

1. Secure your footing and engage the chain brake when you are starting the chain saw.
2. While you are working in a tree, the chain saw shall be tethered to the tree or to yourself at all times to prevent it from falling. Chain saws weighing more than 15 pounds (service weight) shall be supported by a separate line and shall not be attached to you. Breakaway chain saw lanyards are available commercially for saws weighing 15 pounds or less. These lanyards break when 200 to 250 pounds of force is applied, such as when the lanyard is snagged by a falling branch.
3. When using a chain saw in a tree, secure yourself to the tree with a minimum of two systems. One of the systems shall be cut resistant (steel-core lanyard or chain); the other system should be an attached safety, climbing, or rappel line. Care should be taken to keep slack out of lanyards and the climbing system, and to keep all lines clear of falling limbs or tops.
4. When topping or trimming a large section of a tree, or in tree species that readily “barber chair,” a securing system (log chain, ratchet strap, etc.) should be used around the bole of the tree just above, and below, the point where the cut is to be made.
5. Engage the chain brake and take your hand off the throttle while moving between work locations in the tree. The saw need not be stopped between cuts during consecutive cutting operations where there is secure footing. Stop the engine when you are making long moves in a tree, such as when you must release the lanyard.
6. Maintain a firm grip on the chain saw with both hands when you are sawing. Keep your thumb encircling both handles to avoid losing control in the event of a kickback.
7. Keep ropes, lanyards, and your body out of the cutting or kickback zone—especially when you are making plunge cuts.
8. Always be fully aware of the cutting zone, and never make “blind cuts,” where the saw can come in contact with the climbing line or work-positioning lanyard.
9. When carrying a rappel line and a chain saw up a tree, attach the saw on the opposite side of your belt from the rappel line to avoid damaging the rope.
10. When repositioning the saw, or when the saw may contact a lanyard or climbing line, the chain brake shall be engaged. NEVER cut across a lanyard or rope.
11. See FSH 6709.11, Health and Safety Code Handbook, Section 22.48, Chain Saw Operations, for related information.

4. Climbing Safety—Equipment, Systems, and Procedures—Notes

5. Climbing Equipment—Use and Care

Use of Climbing Equipment. A variety of equipment has been developed for tree climbing work or adapted from activities such as rock climbing and caving. The climbing assignment and personal preference largely dictate the equipment selected. This chapter contains information on recommended uses, advantages and disadvantages of equipment, procedures for use, and recommendations for care.

Care of Climbing Equipment. Continue to check the condition of your equipment frequently during the climbing assignment. After the job, inspect the equipment and refurbish as needed so it is ready for the next assignment or for emergency use. Restrict equipment access to certified climbers and use the equipment exclusively for tree climbing work. A locked storage area is advisable. Storage areas should be secure from rodents and chemicals—a must for rope, webbing, and harnesses. Clearly mark or tag all defective equipment to prevent further use and repair or take it out of service. Certified climbers should be responsible for all of their own climbing equipment. Keep manufacturers' equipment specifications and care recommendations on file for ready access.

Equipment, especially ropes, webbing, and loops, should never be walked on or driven over. This kind of abuse causes damage in ways that are not always apparent and could cause failures.

Climbing equipment, especially life-safety ropes, must not be left in a tree for an extended period. The equipment needs to be closely inspected before each use, and it cannot be if it is left in the tree. Tree sap, insects, animals, abrasion, sunlight, and rain affect climbing equipment, and equipment cannot be monitored or controlled when it is left in the tree. If a tree will be climbed more than once, a utility cord can be left in a position that allows climbing ropes to be easily put in place for future climbs.

When life-safety equipment shows significant wear, it should be taken out of service. Significant wear could be a frayed leg loop on a harness or a small crack in a gaff. Do not use any safety equipment that was involved in a significant fall. Harnesses, ropes, and any slings or webbing that helped arrest a fall can receive damage that is undetectable during inspection. The climbing components might fail the next time they are used.

Do not paint metal equipment. Paint can hide defects that can cause failure.

5.1 Climbing Spurs

Climbing with climbing spurs (figure 5a) is fast, but the gaffs or spurs can injure the tree bole. Most thick-barked trees can be climbed repeatedly without serious harm to the bole. Use pole gaffs on thin-barked trees and tree gaffs on thick-barked trees. When climbing spurs are not in use, place sheaths over the gaff points to protect equipment and the handler.

Gaff sheaths can be made from a piece of garden hose (figure 5b). Place the gaff in the uncut portion of the hose and place the cut portion around the shank of the climbing spurs. Commercial gaff sheaths are available.

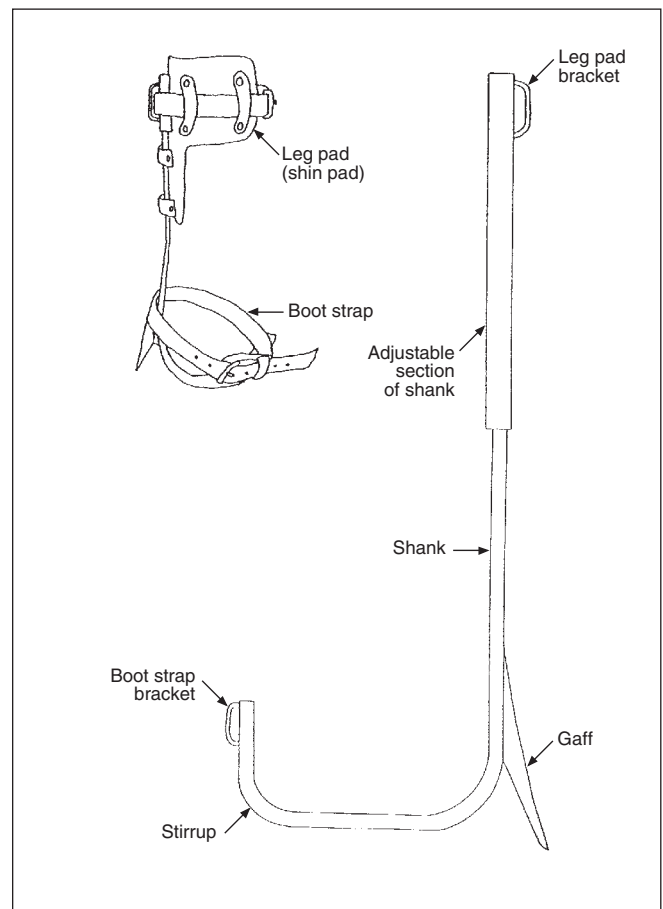

Figure 5a—Parts of a climbing spur.

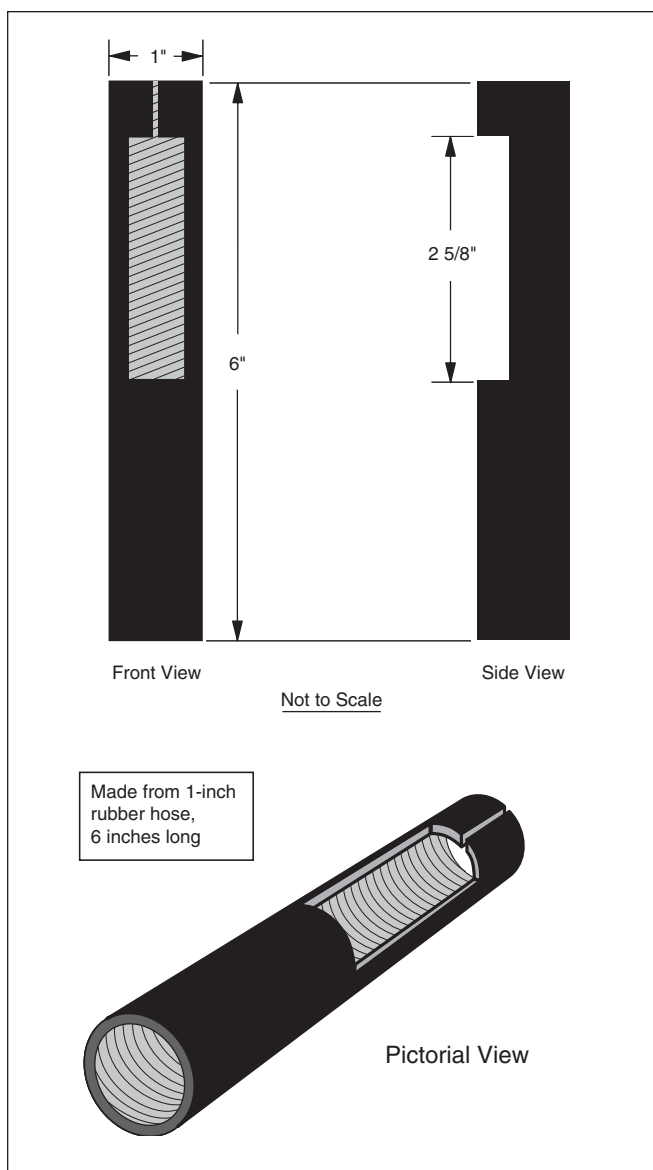

Figure 5b—Sheaths for climbing spurs.

5.1.1 Recommended Uses of Climbing Spurs

- Pruning the tree bole
- Placing pole steps
- Rescuing a climber when ladders are not in place
- Accessing the live crown

5.1.2 Advantages of Climbing Spurs

- Easy and efficient to use
- Relatively inexpensive
- Lighter than some ascending equipment and easily carried over steep or rocky terrain

5.1.3 Disadvantages of Climbing Spurs

- Gaffs may injure the tree bole.
- Gaffs can be a hazard to climbers.
- Gaffs can be a hazard to other climbing equipment, especially rope and webbing.

5.1.4 Procedures for Using Climbing Spurs

1. Mounting climbing spurs on your legs
 - A. Carry the climbing spurs to the base of the tree.
 - B. Remove the sheaths from the gaffs and place them near the base of the tree.
 - C. Place the stirrup on the instep of the boot with the gaffs to the inside of your leg, the shank in an upright position, and the shin pad across the front of your leg.
 - D. Adjust the shank to its most comfortable position on your leg (use a screwdriver or wrench to remove the holding screws and adjust the shank to about 2 inches below your knee).
 - E. Strap on the climbing spurs. Both the stirrup and the leg straps should be snug, but not tight enough to impair circulation.
2. Climbing belt and lanyards
 - A. Standard climbing equipment includes two lanyards. Two lanyards are needed to pass limbs and resolve equipment difficulties safely.
 - B. Wear the climbing belt low on your waist—it should ride on the upper part of your hips.
 - C. Check the steel-core rope lanyard to make sure it is in good shape and is the proper length for the job. With a Becket hitch or mechanical adjuster, fasten one end of a steel-core rope lanyard to a D-ring on one side of the climbing belt. Refer to section 4.1.2 for procedures used with steel-core manila and steel-core nylon rope lanyards.

- D. A safety harness with an integral climbing belt may be used instead of a separate climbing belt. Remember, a safety harness should be worn during all climbing assignments, so if a separate spur climbing belt is used, it should be worn over the safety harness. It is also advisable to attach the climbing belt to the harness to prevent the belt from slipping off your hips during a fall.

3. Ascending and descending the tree

- A. Stand at the base of the tree and pass the lanyard around the tree. Snap the lanyard to the D-ring on the climbing belt on the opposite side of the Becket hitch or mechanical adjuster.
- B. Adjust the lanyard so you can lean away from the tree slightly.
- C. Start climbing, taking short steps while keeping your knees bowed slightly outward. Do not jam the spurs into the tree. Settle the gaffs into the bark on the face of the tree rather than on its sides, where the bark can flake off easily. Gaffs placed at an angle may also flake off the bark.
- D. Keep the lanyard between your waist and chest by flipping the lanyard upward while ascending the tree. Pull your body toward the tree bole with both hands, firmly grasping the lanyard near the bole on both sides of the tree. With a quick, smooth, outward and upward motion of your hands, flip the lanyard away from the bole and up the tree. Smoothly allow your body weight to return to the lanyard and safety harness. **NEVER ALLOW THE LANYARD TO FALL BELOW YOUR WAIST.**

On very large trees, two climbers may need to climb on opposite sides of the bole, each moving the other's lanyard as they ascend. Adjust the lanyard length periodically to compensate for bole taper using the procedure described in section 4.1.2.2.

- E. Where practical, prune or knock off dead branches and branch stubs on the way up to the free-climbing portion of the live crown. You must be supported at all times by a lanyard until you enter safely into the live crown. Pass limbs using the limb-over procedures described in section 4.1.2.4. Repeat limb-overs as needed until you reach the free-climbing portion of the live crown. To ensure proficiency, practice limb-over procedures before climbing.
- F. Use the reverse procedure for descending. The gaffs must penetrate the bark to solid wood. Otherwise, the bark may flake off when you apply your weight, leaving you with no support. Take care

not to jam gaffs too deeply, making them difficult to remove. You may need to adjust the lanyards as the bole diameter increases. Due to the hazards associated with gaffs during descent, it is generally safer to rappel down, if possible.

- G. When dismounting from the tree, step to the ground (do not jump). Regain balanced footing before releasing the lanyard.
- H. After dismounting, immediately remove your climbing spurs and place sheaths over the gaffs. To minimize the danger of personal injury or damage to the equipment, *never walk around while wearing climbing spurs.*

4. Climbing and working in the live crown

- A. It is generally better to remove your spurs at the base of the live crown. However, if you intend to wear the climbing spurs while in the live crown:
- When safely into the live crown, use a modification of the three-point climbing system. (The points of contact are climbing spurs with the gaffs firmly placed in the bole and hands holding sound, live branches that support your weight.)
 - Avoid stepping on branches in the tree. The steel stirrups may skin the branches, leaving a slippery surface, or the gaffs may hang up.
 - Use a lanyard when working.
 - Do not climb above the 6-inch-bole-diameter level with spurs.
 - To avoid injury, take special care while climbing with climbing spurs in the live crown.
- B. If you are going to remove your climbing spurs, either lower them to the ground or tie them to the tree after you are safely in the live crown. Proceed using the three-point climbing system described in section 4.2.1. Whether the gaffs are lowered to the ground or left in the tree, the gaff points should be covered to prevent damage to safety lines.

5.1.5 Care of Climbing Spurs

1. Keep sheaths on the gaffs when the gaffs are not being used.
2. Store climbing spurs separately from other climbing equipment.
3. Inspect climbing spurs before and after each use for potential problems such as:

5. Climbing Equipment—Use and Care

- A. Metal fatigue or broken parts.
 - B. Loose or missing screws. (Tighten and replace as necessary.)
 - C. Improper mounting of straps and leg guards or loose strap loops and damaged or missing straps.
 - D. Loose, dull, or improperly shaped gaffs.
 - E. Improper gaff length. Gaffs should be at least $1\frac{1}{8}$ inches long when measured along the inner surface.
 - F. Gaffs of different lengths. There should be no more than a $\frac{1}{8}$ -inch difference in the lengths of the gaffs on a pair of climbing spurs.
4. Keep climbing spur sets together. Fasten them together when they are stored or transported.
 5. Keep gaffs sharp and maintain the gaffs' original shape as closely as possible during sharpening (figure 5c).
 6. Check spurs for proper fit before each use and make adjustments if needed.

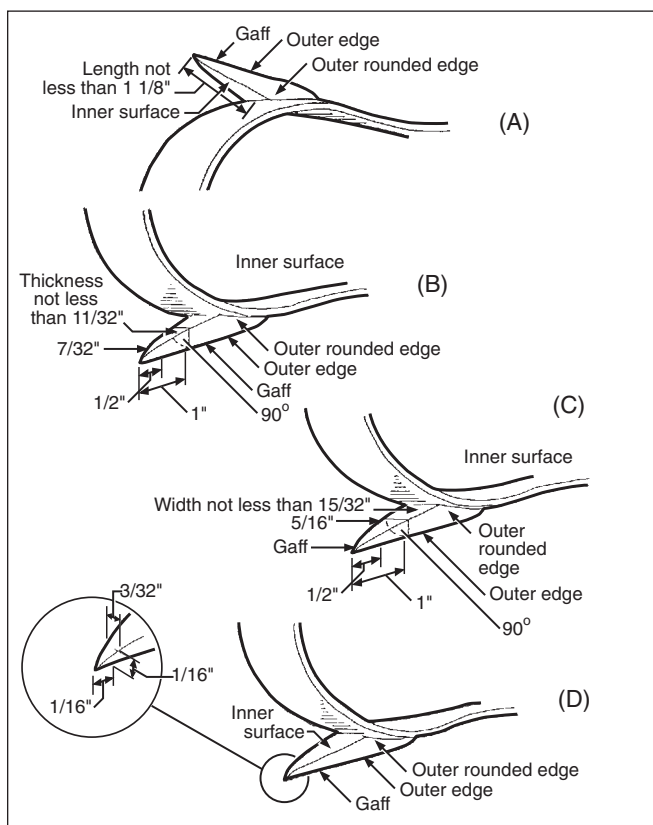

Figure 5c—Gaff parts.

5.2 Ladders

The two types of ladders most suitable for tree climbing are the tripod orchard ladder and the Swedish sectional tree climbing ladder (or an equivalent design that may be stacked by placing stout prongs projecting from the rails at one end of the ladder section into receptors in the rails at the end of an adjacent ladder section). Other types of ladders are not as secure when stacked, increasing the potential for climber injury. This section deals only with the two ladder types previously mentioned. Metal ladders should be prominently marked with electrical hazard warning labels that read: "Warning—Do Not Use Around Electrical Equipment."

5.2.1 Recommended Uses of Ladders

1. Tripod orchard ladders
 - Seed-orchard work in small trees
 - Easily accessible work in small trees
2. Sectional tree climbing ladders
 - General tree work in larger trees
 - Whenever more than one person must ascend a tree or when a number of ascents are needed to complete the project

5.2.2 Advantages of Ladders

- Easy to use
- Can be used repeatedly until the job is completed
- Provide easy access into the live crown
- Cause little or no damage to the tree bole

5.2.3 Disadvantages of Ladders

- Tripod orchard ladders are no taller than 16 feet and are difficult to carry and use in the forest.
- Sectional ladders are difficult to pack over steep or brushy terrain or for long distances.
- Sectional ladders are expensive compared with climbing equipment used in other methods.

5.2.4 Procedures for Using Ladders

Do not climb wet ladders or ladders covered with ice or snow. Footwear must have rubber or neoprene soles and should be dry. Only one person should be on a ladder at any time. When raising and lowering a large number of sectional ladders, use a pulley haul system (see section 5.2.4.3).

1. Tripod orchard ladders
 - A. Place the base of the ladder and the tripod on firm ground after checking for rodent burrows or other hazards.
 - B. Place the base of the ladder on relatively even ground.
 - C. Incline the ladder at an angle that provides adequate stability (no more than 50 degrees from horizontal). The distance between the foot of the ladder and the point on the ground directly beneath the upper support point should never be less than one-quarter the total length of the ladder (figure 5d).

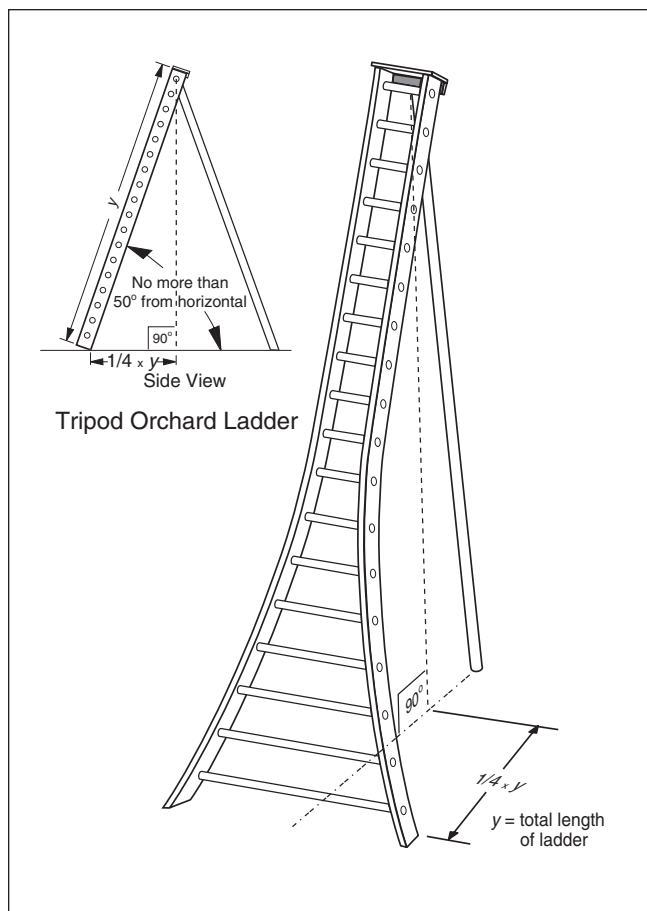

Figure 5d—Tripod orchard ladder.

- D. Check the stability of the ladder by standing on a lower rung.
 - E. Climb the ladder using the three-point climbing system.
 - F. Use two people to move large tripod ladders.
 - G. Transport ladders in the horizontal position when moving them more than a few feet.
2. Sectional tree climbing ladders
 - A. Set the legs of the base-ladder section on firm, nearly level ground against the base of the tree. Put your weight on the bottom rung and settle the ladder base into the ground to minimize settling as sections are added. Live branches may need to be cut to position the top section of the ladder between live branches for safe climbing into the live crown.
 - B. Push no more than two sections up from the ground when erecting the ladder. Afterward, hoist only one section at a time with a haul line.
 - C. Place a lanyard around the tree and secure it to a climbing belt or safety harness, leaving little slack in the lanyard, when erecting and climbing unsecured ladders. Keep the lanyard fastened until the ladder section's chain or strap is secured around the bole. You may need a second lanyard to limb-over branches. When erecting ladder sections:
 - Adjust the lanyard so you can lean slightly back from vertical. This position allows better balance while you raise the ladder section into position.
 - Position yourself on the secured ladder section with the spacer bracket about chest high to erect additional ladder sections. This will permit you to place the next section without lifting it over your head.
 - Maintain control of the section by walking or sliding the top of the ladder up the bole while keeping the base of the section away from the bole. This puts most of the weight on the tree. On rough-barked trees, you may have to flip the ladder around so the spacer spikes face away from the bole.
 - Take care to avoid being struck with the dangling attachment chain.
 - If you cannot maintain control of the ladder, let it go. Don't risk injury by trying to regain control. Warn the ground person before letting go of the section.

5. Climbing Equipment—Use and Care

- D. Pass the chain of the ladder section around the tree. The chain must be placed as horizontal as possible to minimize the possibility that the chain could become slack, leaving the ladder section insecure or unstable. To tighten the chain (when the fastening bracket is on the right side of the ladder), push on the right side of the ladder with your left hand and your right foot or knee. Using a rocking motion, pull back on the chain. When the chain is taut, secure it to the ladder. You may need to twist the chain to shorten it and to repeat the above procedure to secure the ladder firmly, but each ladder section must be secured firmly to the tree bole.
- E. Secure the chain by knotting it around the bracket and itself so it cannot slip out of the fastening bracket. A tire chain fastener with a locking device, a turnbuckle system, or a tie-down strap with a ratchet tightener are all recommended instead of the manufacturer's system (figure 5e).

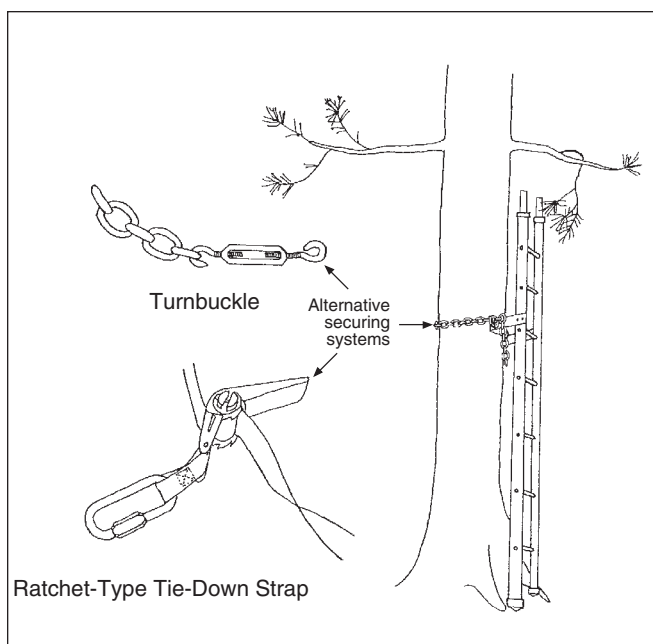

Figure 5e—Sectional tree climbing ladder.

- F. Fasten the chain for each succeeding section as described in paragraphs D and E.
- G. Use a saw or a branch bat (a short bat on a thong) to prune dead branches and stobs. Never use ladder sections to break off dead branches.

- H. Climb ladder sections using the three-point climbing system without a lanyard only after the sections have been secured.
- I. Secure yourself with a lanyard around the bole or to a rappel system when dismantling ladders.
- J. Do not leave ladders unattended in trees.

3. Pulley haul system

Pulleys, when combined with a haul line, can be used to raise and lower tree climbing ladder sections. Lightweight pulleys (commonly called “rescue pulleys”) are most suitable. This haul system can also be used to raise and lower tools, equipment, tree cones, and similar materials.

The pulley haul system allows the ground person to raise gear to a climber, as well as to control the gear's descent. It's easier to haul the materials from the ground than from the tree, and the ground person can be hauling materials while the tree climber is busy with other tasks. The pulley haul system also

- provides a safe method for raising and lowering large numbers of sectional ladders,
- reduces abrasion on haul lines and rappel lines,
- reduces the physical effort needed for handling materials,
- saves time by allowing the ground person to control the material's descent, and
- permits tree climbers to climb with minimum gear.

Rescue pulleys come in a variety of styles, weights, and strength ratings. Pulleys are inexpensive and available from a variety of manufacturers, wholesalers, and retailers (such as mountaineering suppliers).

To use a pulley haul system:

- A. Use a haul line that is longer than twice the maximum climbing height (required for a doubled haul line). Static kernmantle utility line is recommended because of its handling characteristics.
- B. Form loops at each end of the haul line by tying a figure eight on a bight. Attach a carabiner to each loop to prevent either end of the haul line from accidentally passing through the pulley.
- C. Pass the haul line through the pulley and attach it to a snap catch or a carabiner on the climber's safety harness during the ascent.

- D. The climber ascends the tree. Temporarily secure one end of the haul line to the ground. When the haul line carabiner is secured at ground level, the climber should avoid weaving through the branches while ascending the tree. The straighter the haul line's path, the easier it will be to raise and lower materials. If the climber intends to lower materials before having material raised, the climber may keep the end of the haul line.
- E. The climber removes the pulley from the harness and secures it with a sling to the bole or a sturdy branch. The climber must be careful not to drop the haul line. The pulley system may be left attached to the climbing harness when raising or lowering lightweight materials.
- F. Attach material or equipment for the climber to the carabiner at the end of the haul line, then pull on the haul line, raising the material.
- G. After the climber attaches materials to the carabiner on the haul line and signals the ground person, the ground person takes control of the haul line and lowers the material safely to the ground. Use a Münter hitch or belay plate to lower heavy objects in a controlled manner.
- H. The climber and the ground person will need to work together (moving the haul line up, down, or sideways) to prevent materials from hanging up on limbs during long hauls.
7. Before each use, make sure the prongs on stacking ladders fit firmly into, but do not bind in, the receptors. Remove burrs and sharp edges from the prongs.
8. Take precautions to avoid dropping ladders while they are in use or during transport. Do not risk injury by attempting to stop an out-of-control ladder section that is falling from a tree.
9. Before using ladders, ensure that the attachment hardware is complete and in good working order. This includes turnbuckles, chains, and ratchet straps.
10. Pad and secure ladders when transporting them in or on vehicles.
11. Transport ladders with the chain and turnbuckles in the truck bed. Turnbuckles sometimes shake off and will be lost if they are hanging out of the truck bed.

NOTE: A carabiner may be used in place of the pulley. The additional friction may help when lowering materials, but makes raising them more difficult. The pulley increases the safety and efficiency of the haul system and is preferred.

5.2.5 Care of Ladders

1. Store ladders indoors in a dry location, either on a flat surface or standing nearly vertical with no weight on the span.
2. Remove dirt and pitch after each use.
3. Keep electrical warnings on metal ladders legible.
4. Oil the bearing points on metal tripod ladders periodically.
5. Before each use, inspect ladders for defective parts and for cuts, dents, bends, or burrs on the rungs and rails.
6. Inspect all screws, nuts, and bolts to ensure that they are securely tightened before use. Inspect rivets that hold the upright prongs on sectional ladders.

5.3 Pole Steps

Metal pole steps, similar to those used on wooden utility poles, may be placed into the bole to provide access to the live crown and to bridge gaps between live branches.

5.3.1 Recommended Uses of Pole Steps

Pole steps are usually installed only when a tree will be climbed repeatedly over a period of years.

5.3.2 Advantages of Pole Steps

- Once pole steps are installed, the tree can be climbed repeatedly without using climbing spurs, ladders, or Swiss Tree Grippers to reach the live crown.
- Pole steps can be positioned below the 4-inch-bole-diameter level in the live crown to make free climbing easier.

5.3.3 Disadvantages of Pole Steps

- Installation and maintenance are expensive.
- The steps must be removed when no further work is planned in the tree.
- When installed properly on a thick-barked tree, the working surface may be narrow.

5.3.4 Procedures for Using, Installing, and Maintaining Pole Steps

1. Use the three-point climbing system when relying on pole steps for support.
2. Wear a safety sling attached to your harness at all times when climbing and using pole steps for support. This provides a quick means of securing a climber in an emergency.
 - A. Construct a safety sling from flexible rope or webbing to form a finished product with at least a 5,400-pound minimum breaking strength (see section 8.5). The sling should be 1- to 1½-feet long so it reaches easily from the safety harness tie-in point(s) to the nearest pole step.
 - B. Fasten one end of the sling securely to the safety harness tie-in point(s). The other end of the sling should have an adjustable loop so it can be tightened quickly around a pole step (figure 5f).
 - C. In a climbing emergency, slip the adjustable loop over the nearest pole step and tighten the loop. This loop must retain its open shape while it is not being used and must be easy to tighten with one hand. It is advisable to have two slings attached to the safety harness so they can be attached to separate pole steps, providing horizontal stability and vertical support.
3. When possible, place pole steps during the tree's dormant season.
4. Space pole steps about 14 inches apart from each other or about 28 inches between pole steps on the same side of the bole (figure 5g). On a tree with sweep, place pole steps on the outside curve of the sweep.
5. During installation, prune branches and branch stubs up to the portion of the bole in the live crown where you will be able to transfer your weight safely from the pole steps to the live branches. Use ladders, Swiss Tree Grippers, or climbing spurs for this procedure.
6. Place pole steps as follows:
 - A. When using Swiss Tree Grippers, ladders, or climbing spurs, start at the base of the live crown and work down the bole.
 - B. When using pole steps for support, climb up the bole using the pole steps as they are placed. Your safety sling(s) can be used for support while placing pole steps in this manner.

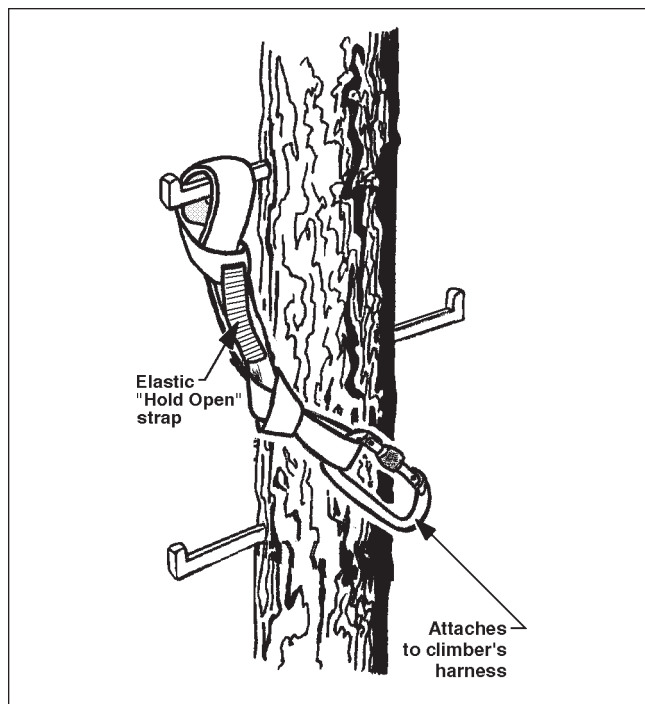

Figure 5f—Pole steps.

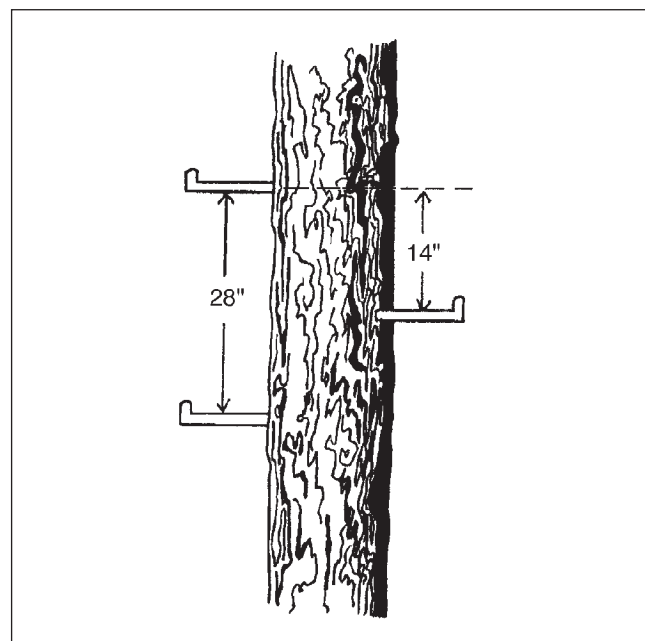

Figure 5g—Pole step spacing.

7. Place the lowest pole step at least 8 feet off the ground.
8. Drill a 3- to 5-inch-deep horizontal hole, slightly smaller in diameter than the pole step, in the proper position on the tree.
9. On thick-barked trees, cut away some of the bark to provide a wider working surface after the pole step is installed.
10. Place pole steps into the drilled holes and pound the pole step in with a 2¹/₂- to 3-pound hammer until 6 inches of the pole step remain exposed.
11. Using a wrench, turn the pole step in 1 inch farther, leaving the turned end facing up. The distance from the end of the pole step to the bole should be about 5 inches.
12. As needed, back out the pole steps with a wrench or length of ³/₄-inch pipe to compensate for tree growth. Remove lower branches if they have died and place additional pole steps as needed.

5.3.5 Care of Pole Steps

Before placing weight on pole steps, check for

- signs of metal fatigue
- firm anchoring in the tree
- adequate step length for bearing weight

Replace or adjust pole steps as needed.

5.4 Swiss Tree Grippers

The Swiss Tree Grippers, equipped with 8-foot-10-inch steel bands, can be used to access the live crown without damaging the tree. While carrying or storing the grippers, immobilize the pivot point between the hinge head and the shank with the lashing between the hinge head and the contractor. When climbing with Swiss Tree Grippers, do not place your fingers under the bands. (Refer to figure 5h for the location of the parts on Swiss Tree Grippers.)

The Swiss Tree Gripper climbing belt with steel cables is recommended. However, you may use other suitable climbing belts or a safety harness. Use only steel cable or steel-core lanyards because the bands can cut through synthetic or natural fibers. A lanyard must be passed around the tree and secured to a suitable safety harness (or climbing belt over a safety harness) before attaching the

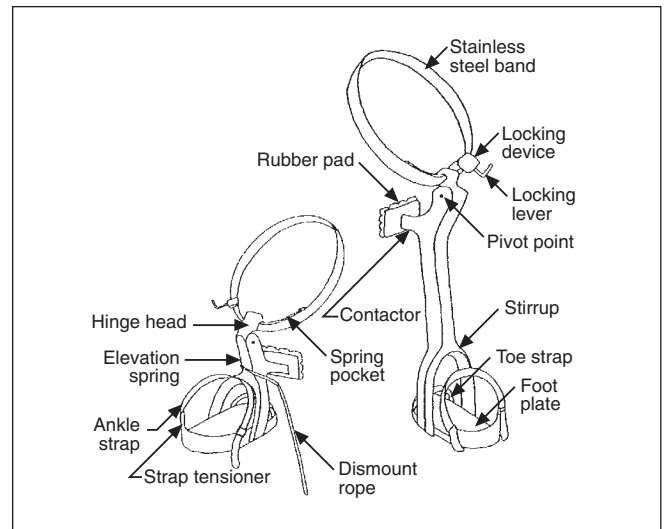

Figure 5h—Swiss Tree Grippers.

grippers to the feet. A lanyard must be secured around the tree at all times when wearing the grippers to avoid injury if you lose your balance.

5.4.1 Recommended Uses of Swiss Tree Grippers

- General tree climbing work in trees under 26 inches in diameter
- Pruning
- Placing pole steps

5.4.2 Advantages of Swiss Tree Grippers

- Do not damage the tree bole when climbing and working below the live crown
- Reduced muscle fatigue during lengthy pruning projects

5.4.3 Disadvantages of Swiss Tree Grippers

- Difficult to use on small-diameter trees if the grippers are not equipped with short bands. Rubber pads may slip to the side of the bole, resulting in insecure gripper placement.
- Cannot be used on trees larger than 26 inches in diameter unless equipped with long bands.

5. Climbing Equipment—Use and Care

- Only one band size (8 feet 10 inches) is available through suppliers in the United States.
- Very expensive.
- Tree must be pruned of all limbs to the live crown or to the point where the climber can begin free climbing.

5.4.4 Procedures for Using Swiss Tree Grippers

1. Mounting Swiss Tree Grippers on the tree
 - A. Adjust the toe and ankle straps for proper fit.
 - B. Loosen the locking device and place the open end of the band halfway around the tree. Reach to the opposite side of the tree and bring the band the rest of the way around (or have the ground person help you do so). Slide the end of the band behind the elevation spring and through the locking device. Adjust the band, allowing enough slack for the band to slide easily up the tree. Tighten the locking lever. The long gripper is mounted above and to the right of the short gripper. Foot plates should be level with each other after mounting. When the grippers are properly assembled, the band ends will mount in opposite directions.
2. Swiss Tree Gripper climbing belt
 - A. When using the Swiss Tree Gripper climbing belt, adjust it so it fits snugly around your lower waist. The cable adjustment lever goes up and on the right side of the body. A safety harness is a **MUST** during all climbing assignments. Wear the Swiss Tree Gripper climbing belt over a safety harness.
 - B. Check climbing belt hardware to make sure it will work properly.
3. Ascending the tree
 - A. Pass the lower (largest-diameter) lanyard on the Swiss Tree Gripper climbing belt around the tree and lock the end into place on the opposite side of the belt. Adjust the lanyard to a length that allows a natural vertical position, but prevents you from leaning back. Secure the adjustment lever and make sure the lever is completely closed.
 - B. Place your feet on the foot plates and in the toe and ankle straps. Again, check for proper fit and adjust the straps as necessary.
 - C. Close ankle strap tensioners, making sure they are down and secure.
 - D. Check for proper adjustment by placing your weight on each gripper individually.
 - E. Ascend the tree by sliding the safety cable up first (**NEVER ALLOW THE LANYARD TO FALL BELOW YOUR WAIST**), then the right gripper and the left gripper. Repeat this sequence to ascend. Readjust (tighten) the bands on the grippers when your boot toe begins touching the tree.
 - F. Cut away any dead limbs below the live crown with a small folding saw. Remove scattered live branches to reach a safe position to dismount into the live crown.
4. Dismounting into green limbs
 - A. Ascend into green limbs until the band of the right gripper is against the bottom of the lowest green limb.
 - B. Limb-over several times until the bands are against the lowest limb, if necessary. To limb-over, pass the upper (smallest-diameter) lanyard around the tree and above the lowest whorl of branches, securing it in the lock on the opposite side of the climbing belt. Adjust the length of the upper lanyard and disconnect the lower lanyard. Repeat as necessary.
 - C. With the safety lanyard still in place around the tree, tighten both gripper bands as tightly as possible just below the lowest green limb.
 - D. Tie the dismount rope from the lower gripper to the green limb. Do not allow slack in the rope.
 - E. Unfasten the ankle-strap tensioners, slip your foot out of the toe strap, and climb into the tree.
 - F. When safely in the tree, keep one lanyard around the tree and firmly attached to the safety harness. You may remove the Swiss Tree Gripper climbing belt. After doing so, secure the climbing belt in the tree for the descent. If you plan to rappel from the tree, the Swiss Tree Grippers and climbing belt may be lowered to the ground with a haul line.
 - G. Climb to the work position using the three-point climbing system.
5. Remounting and descending
 - A. Pass the lanyard around the tree and secure it to the safety harness. If the Swiss Tree Gripper climbing belt is to be used, secure it around your waist.
 - B. Move into position above the grippers.

- C. Pass the upper Swiss Tree Gripper climbing belt lanyard around the tree above the lowest live branches and secure it in the lock on the opposite side of the safety belt. Once this lanyard is in place, you can release the safety harness lanyard.
 - D. Step into the foot plates and tighten the toe and ankle straps. Make sure the tensioners are down and secure.
 - E. Unfasten the dismount rope.
 - F. Individually loosen the bands slightly to allow them to slip over the bole.
 - G. When in position, pass the lower Swiss Tree Gripper climbing belt lanyard around the tree below the lowest live branch and secure it in the lock on the opposite side of the safety belt.
 - H. Disconnect the upper Swiss Tree Gripper climbing belt lanyard and descend the tree, adjusting gripper bands and the lower lanyard as needed.
 - I. Descend until both foot plates are on the ground.
 - J. Release the ankle straps and step out of the Swiss Tree Grippers before unfastening the lanyard.
6. Removing the Swiss Tree Grippers from the tree
- A. Loosen the locking lever on the band.
 - B. Slide the band out of the locking device.
 - C. Pass the band halfway around the tree. Reach to the opposite side of the tree and bring the band around the rest of the way.
 - D. When the grippers are off the tree, pass the band end through the locking device twice and secure the locking lever.
 - D. Make sure the strap tensioners work smoothly and are not bent.
 - E. Make sure the dismount rope is in usable condition.
 - F. Check the climbing belt for frayed or broken stitching.
 - G. Inspect the lanyards for kinks, knots, and fraying.
 - H. Check the snaps and the cable lock on the safety belt for proper functioning.
 - I. Check for the cotter pin inside the locking device on the locking lever.
2. Daily Inspection
- A. Inspect the rubber pads for wear and tear.
 - B. Make sure all screws and nuts are in place and tight.
 - C. Look for the evidence of metal fatigue at the midpoint in the foot plate, midpoint in the stirrups, around the pivot bearing, and on the contractor.
 - D. Check the leather straps for drying and cracking.
 - E. Make sure the threads on the locking lever are not stripped.
 - F. Make general inspections for other possible problems.
3. Preventive maintenance
- A. Replace worn and defective parts.
 - B. Remove any dried pitch from the bands and oil lightly.
 - C. Clean all metal parts and lightly oil parts subject to rust.

5.4.5 Care of the Swiss Tree Gripper System

Refer to figure 5h for the location of the parts on the Swiss Tree Grippers.

1. Inspection before each use
 - A. Remove any pitch on bands with hand cleaner or other suitable solvent (use gloves, and perhaps an apron and face shield).
 - B. Make sure the bent end of each band is lapped over the retainer in the correct position.
 - C. Check to see that the cotter pin is in place on the pivot bearing.

5.5 Ascenders

An ascender is a mechanical device or a friction knot that is designed to allow you to ascend a vertically fixed rope. The Blake's hitch is the preferred knot for ascending with the hip thrust (also called body thrust) and can also be used for the secured footlock. Mechanical ascenders may be either the handle-attachment type or the cam-attachment type, depending on where the support sling is attached to the ascender. Handle-attachment ascenders may be right- or left-handed. Cam-attachment ascenders may be used in either hand (figure 5i).

5. Climbing Equipment—Use and Care

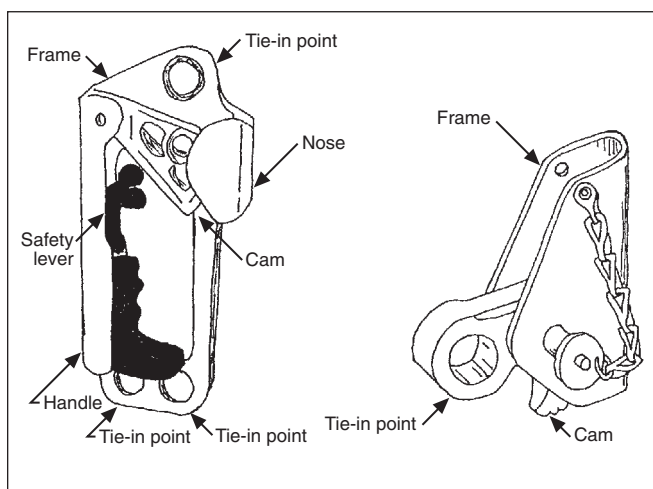

Figure 5i—Handle attachment ascender (left) and cam attachment ascender (right).

Parts of these mechanical ascenders include:

1. **Frame.** The main component to which the other parts of the ascender are attached. The rope passes through the frame.
2. **Handle.** May either be an integral part of the frame or attached to the frame with rivets or bolts. Some handle-attachment ascenders may lack a true handle. Cam-attachment ascenders do not have a handle.
4. **Nose.** The part of the frame that forms the inside channel into which the cam pushes the rope.
3. **Safety lever.** Prevents full downward movement of the cam when in the locked position. This is designed to keep the ascender from coming off the rope accidentally.
5. **Tie-in points.** An integral part of the frame used to attach your support sling. Some ascenders also have an additional attachment point at the top so that the ascender is pulled along as you climb the rope. You tie in directly to the cam when using a cam-attachment ascender.
6. **Cam.** The internal pivoting metal piece (sometimes equipped with small teeth) that pinches the rope against the frame. The cam may be spring loaded or free running. A spring-loaded ascender generally provides a more secure attachment to the rope. Free-running ascenders may be more convenient in some applications.

Ascenders are attached to the safety harness and to your body using slings made from webbing or rope that meets or exceeds the 5,400-pound breaking strength requirement (see sections 8.4 and 8.5). Rope slings should be constructed from static rope because of its low stretch characteristics. Webbing slings should be sewn or tied into a loop to meet breaking-strength requirements. It is important to inspect slings often for signs of wear and abrasion.

5.5.1 Recommended Uses of Ascenders

Ascenders should be used only when other climbing methods are more difficult or dangerous or to protect ornamental trees. The safety of the ascent depends heavily on the strength of the branch that supports the rope you are ascending. Select a branch that is strong enough to provide a margin of safety while withstanding the forces placed on it during an ascent (size varies with species). Ascenders are used most often in hardwoods; old-growth, large-diameter conifers; and trees with high ornamental value.

5.5.2 Advantages of Ascenders

- Skilled climbers can ascend a large-diameter, difficult tree faster, with less effort, and generally more safely than with other methods.
- Equipment is lighter and less cumbersome. These features are important when a lengthy hike is required to reach the tree.
- Ascenders may be the easiest and most effective way to climb multiple-stemmed trees, such as hardwoods.
- Hardwood crowns can be worked with a single length of climbing rope.
- Hip thrust and secured footlock techniques can allow rapid ascent and descent in case of attack by bees or raptors or if necessary because of other tree hazards.
- Lower cost.

5.5.3 Disadvantages of Ascenders

- The safety of the ascender system depends on the climber's evaluation of the supporting branch while the climber is still on the ground.
- Installing the rope in the tree is difficult and time consuming if the installation point is over 90-feet high in thick stands of trees or in wide-spreading branches of hardwoods.

- Hip thrust and some secured footlock methods abrade rope and may require the rope to be retired after as little as 200 hours of use.
- Suitable anchor points for the rope may be difficult to find in some trees.
- Long hair or baggy clothes may get caught in ascenders.

5.5.4 Procedures for Using Ascenders

1. Assess the potential for using ascenders
 - A. Can the tree be climbed more safely with other types of climbing equipment?
 - B. Are there suitable branches capable of supporting your weight or tree crotches over which to anchor the ascender rope? Downward-sloping limbs will generally prevent secure rope placement. Your life depends on these branches.
 - C. Can you make a smooth transition from the ascenders into the live crown of the tree? A fall at this point can put a severe strain on the rope from the ascender cam.
 - D. Are there dead branches or branch stubs that could cause injury?
2. Securing the ascender rope over a suitable live tree branch
 - A. A suitable live tree branch must be capable of supporting your weight. Choosing a suitable branch comes with experience. Anything smaller than 3 inches in diameter for a hardwood branch crotch or 4 inches for a conifer branch should be studied carefully. Binoculars can help.
 - B. The branch or crotch must be located within the live crown area for a smooth dismount into the live crown. Never select a branch that is located at the base of the live crown.
 - C. Various methods are used to position the ascender rope over a suitable tree branch. Some common methods include:
 - *Noose knot or monkey's fist knot.* Large knots that provide enough weight for you to throw the rope up to 30 feet high.
 - *Throwbag and line.* A small-diameter haul line attached to a small weight can be thrown over a suitable live branch. With 3 to 4 hours of practice, you can throw the line up to 75 feet with accuracy. This method also allows you to reposition the rope while you are in the tree.
 - *Bow and arrow.* Used when suitable live branches are higher than can be reached by throwing a weighted line. A small-diameter haul line attached to an arrow is shot over a suitable branch. A bow fishing reel with a blunt-tipped fiberglass arrow (for weight) is ideal for this method and may be the least expensive option for reaching high limbs.
 - *Line gun.* Designed to shoot a small-diameter haul line long distances. It can place a haul line over a branch accurately. Line guns cost several hundred dollars and are considered firearms.
 - *Fishing pole.* Used when there is enough room to accurately swing the pole.
 - *Slingshot/wrist rocket.* When used with either light utility cord or fishing line, this method can be very accurate in areas where throwing space is limited. Commercially available slingshot-type devices can throw a weighted line over a hundred feet.
 - D. Static kernmantle rope is best used for mechanical ascenders because of its low stretch characteristics. This results in a smoother ascent with fewer bounces that stress the anchoring branch and the rope fibers. Braided arborist rope is best for the hip thrust or secured footlock methods because of the rope's abrasion resistance and its texture (that facilitates a secure grip in the footlock). Using a haul line that is at least three times the length of the distance from the tree limb to the anchor point, pull the climbing rope over the live branch and back to the ground at the base of the tree.
 - E. The single-rope technique is used for long ascents. When using the single-rope technique with mechanical ascenders, one end of the rope is anchored around the tree or, preferably, a neighboring tree. Attach the standing part of the ascender rope to a securely anchored lowering device, such as a rappel rack or a rescue-8 descender. Tie off the lowering device securely. If the lowering device becomes untied or the anchor fails, the entire system will fail. This system allows the ground person to lower you quickly in case of emergency (figure 5j).

5. Climbing Equipment—Use and Care

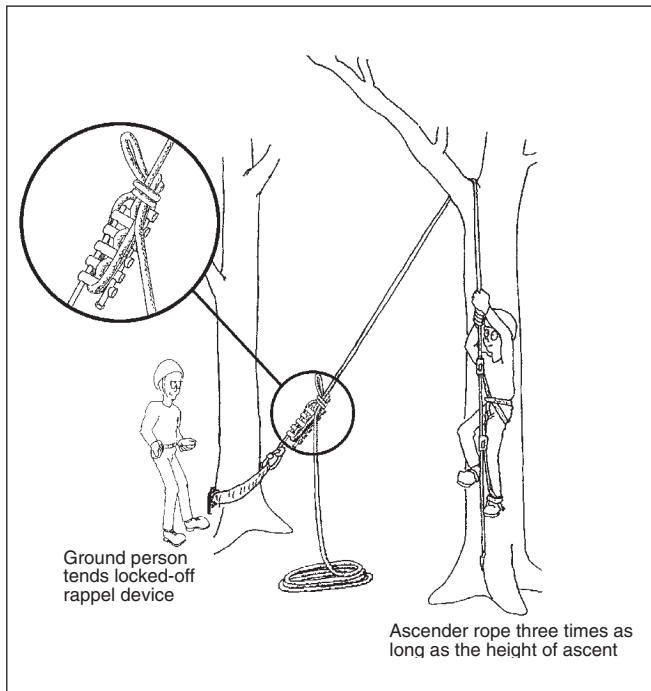

Figure 5j—The single-rope lowering system used with ascenders.

- F. The hip thrust (figure 5k) is most often used when the crothed climbing line lies against or near the tree. It is the most efficient method for hardwood trees where either one short ascent or a series of short rope advances are required. One end of the rope is tied to the harness and a split tail is tied to the other side of the climbing rope with a Blake's hitch. When climbing, place your feet against the tree and thrust your hips upward, pulling down on the rope at the same time. Your progress is secured by the Blake's hitch, which you slide up the rope with one hand. To descend, grab the Blake's hitch with one hand and allow the rope to slide through the hitch with the other hand. (**NOTE:** The Blake's hitch concentrates a lot of friction and abrasion on a short section of rope; descents must be made slowly to limit heat buildup). Check your rope often for wear. It is preferable to use a split tail (a 4- to 6-foot length of rope with a commercially spliced eye) for the Blake's hitch, because the split tail is inexpensive and easy to replace.
- G. The secured footlock (figure 5l) is most commonly used when the rope is away from the bole of the tree. When secured, a friction knot or mechanical ascender is attached to the rope from your harness

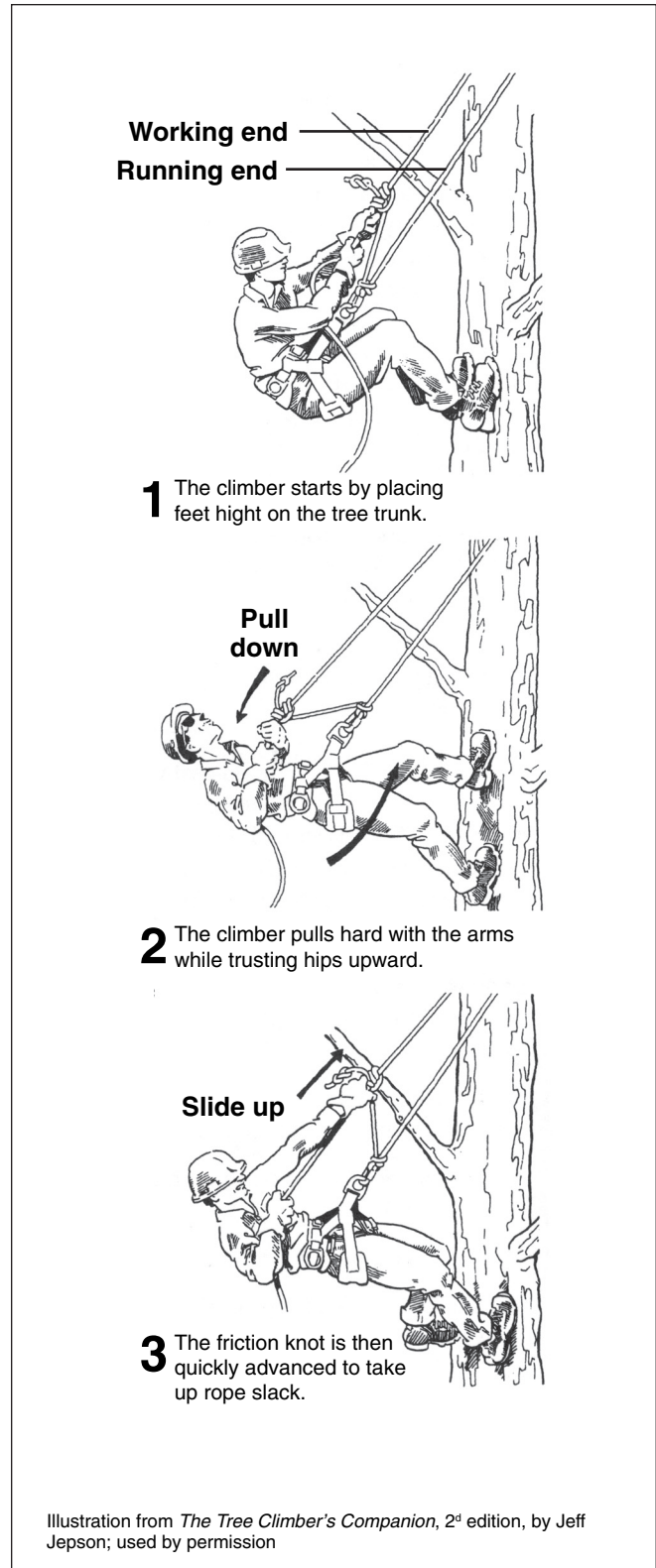
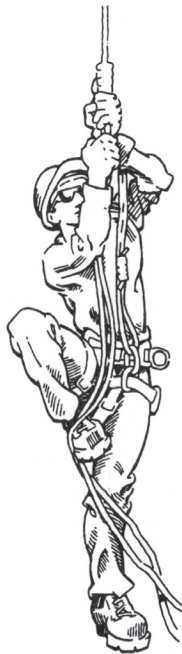

Figure 5k—The hip thrust method.

1 The climber begins by tying the friction hitch to the doubled climbing line with three wraps (six coils) of either a Prusik or a Klemmhiest knot. The other end is attached to the climber's saddle using a double-locking carabiner or rope snap.



2 The climber grabs both ropes with hands below the friction hitch. The rope is placed against the outside of one foot.



3 As the legs are raised, **both** strands of the rope are scooped up with the opposite or lower foot.



4 The rope is then gripped securely between the feet with a wrap around one boot, forming the "footlock."



5 As the climber stands, the friction hitch is advanced and the process repeated.

Handled ascenders may also be used as a means of attachment on the doubled climbing line.

Illustration from *The Tree Climber's Companion*, 2^d edition, by Jeff Jepson; used by permission

Figure 5I—The secured footlock method.

to prevent a fall. There are different ways to set up the system. Wrap your feet around the rope to stand on the rope while the mechanical ascender or knot secures you to the rope. In some systems, the knot is simply a safety backup in case your arms or legs weaken. Other systems use a knot like the Blake's hitch to hold the climber's weight while the feet are being repositioned for the next footlock. The setup can be the same as the hip thrust described above. The climber can alternate from hip thrust to footlock when the climbing line is suspended away from the bole for part of the climb.

3. Constructing a mechanical ascending system

There are numerous methods for using mechanical ascenders. Many systems are described in rock climbing, caving, and rope rescue manuals and books. Whichever system is used, the climber should ensure that there is sufficient redundancy in the system to keep the climber safe if one ascender breaks or comes off the rope. Each ascender should have a sling attached to the rappel point of the climbing harness. If two ascenders are used with only a sling attachment to each foot, the climber would soon be hanging upside down if an ascender came off the rope. With any ascending

5. Climbing Equipment—Use and Care

system, proper sling length and proper setup are critical to efficient operation. Safety loops (chicken loops) fit around the ankle to secure the climber to the system and prevent the foot from slipping out of the sling. They are especially important if an upper attachment fails and the climber falls backward, hanging upside down. A safety loop should fit snugly around the ankle so that it cannot slip over the boot. Some ascents require a mix of three-point climbing and rope ascents. In such cases, it can be difficult and dangerous to attach and remove safety loops while in the tree. Proper inspection before the climb should reveal these potentially dangerous situations.

4. Setting up the system for ascent
 - A. Ensure that the system fits correctly, is intact, and is in good working order.
 - B. Before attaching ascenders to the rope, attach the ascenders to the climber's harness.
 - C. Put the safety loops around your ankles. If you are going to tie these on or attach them with screw links, you may put them on after inserting your foot.
5. Testing the mechanical ascender system and beginning the climb
 - A. To test the system before climbing, alternately put your weight on each ascender to make sure that each one is gripping the rope. Test the tree crotch or branch anchoring your rope by pulling down hard with all your body weight.
 - B. Before the weight of the rope increases below the climber, it may be necessary to have the ground person hold the rope taut from below. As the climber gains altitude (35 to 50 feet), the weight of the rope hanging below the climber is often enough to counteract the upward force of the ascender as it is moved up the rope. When beginning with the lowest ascender, you may need to use your thumb to open the cam before raising the ascender. **DO NOT TOUCH THE SAFETY LEVER.**
 - C. Climb at a steady pace with 12- to 14-inch steps. If you cannot ascend 50 feet in 2 minutes, there is probably a problem with the climbing system and its fit. It must be fine-tuned to your body height and build.
 - D. Do not blindly move ascenders. It is a common mistake to attempt to lift the ascender on which the climber is standing.
 - E. During the ascent, you may encounter branches that are difficult to pass. Use the upper ascender

to pass the limb by turning your back to the limb. Sometimes the rope can be pulled away from the branch with one hand while the other hand slides the ascender above the branch. A final option is to remove the upper ascender from the rope and position it above the branch. **Never prune (cut or saw) branches while using ascenders.**

- F. Having reached the top of the rope, pass a lanyard around the bole of the tree or suitable branch and place your feet and/or hands on limbs to maintain three points of contact while removing ascenders from the climbing rope.
- G. Sometimes you must descend by using mechanical ascenders. For short distances you can “thumb” the cam by pulling down on the cam and sliding the ascender down the rope. Be careful not to touch the safety lever while doing this or the ascender could slip off the rope. If you are using toothed ascenders on braided rope, it is easy to pull strands of rope when sliding the descender down the rope. For long descents, it is better to change over from the ascent system to a rappel system. This is accomplished by attaching a rappel device to the climbing rope below the ascenders and locking it off. Slide the ascenders down until all your weight is on the locked-off rappel device. You may have to remove an ascender from above the rappel device and place it back on the rope below the rappel device. Once all your weight is on the rappel device, you can remove the ascenders from the rope and rappel down the rope. Don't expect to execute a changeover without practicing beforehand. It is a good safety practice to always be prepared to ascend when rappelling (for example, if clothes get stuck in your rappel device) or to rappel when you're ascending (for example, if agitated animals attack you while you are on the rope).

5.5.5 Care of Mechanical Ascenders

Ascenders should be kept clean and oiled as directed by the manufacturer. Dropping or mishandling ascenders may damage them. Before each use, inspect the slings attached to the ascenders for wear and abrasion and for loose knots.

Ascenders may fail when misused. The most common types of failure are:

1. *Frame breakage.* The frame can crack under a painted surface without showing sign of damage. As with other climbing equipment, it is important to know the ascender's complete history.

2. *Rope damage.* Damage can occur when the rope sheath is extremely worn or when stress on the ascender causes the cam's teeth to tear the rope sheath. Sheaths have been known to tear with as little as 800 pounds on the ascender and rope. Handle-attachment ascenders should never be used to support more than one person's weight (such as in rescue hauling systems).
3. *Rope slipping out of ascenders.* When you are ascending, never touch the safety lever unless you want the ascender to come off the rope. Ascenders are designed to operate safely only on vertical ropes and only when moved in a direct line with the rope. Handle-attachment ascenders may slip off the rope when they are pulled away from the rope. This could happen when a rope is at an angle, such as when ascending between tree limbs, or when the rope is tied off away from the base of the tree.

5.6 Tree Steps

Tree steps are lightweight metal platforms that include a length of chain to attach them to the tree bole (figure 5m). A lanyard must be used at all times when using tree steps for support. The three-point climbing system must be used when climbing with tree steps.

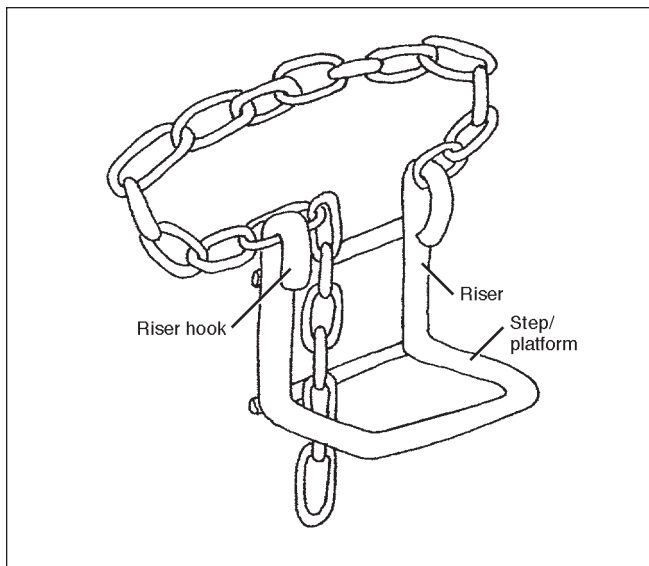

Figure 5m—A tree step.

5.6.1 Recommended Uses of Tree Steps

Tree steps bridge gaps between live branches and provide access to the live crown.

5.6.2 Advantages of Tree Steps

- Once installed, the live crown can be accessed repeatedly without climbing spurs, ladders, or Swiss Tree Grippers.
- Tree steps can be positioned below the 4-inch-bole-diameter level in the live crown for free climbing in the tree.
- Tree steps are lightweight and portable.

5.6.3 Disadvantages of Tree Steps

- Inefficient for long ascents.
- Foot placement is not very secure.

5.6.4 Procedures for Using Tree Steps

1. Determine the best position for the tree step, then pass the chain around the bole and pull it as tightly as possible. Be sure the chain is level and is not hung up on any obstructions on the back side of the tree.
2. Hold the tree step upside down. While pulling tightly on the chain, allow the open end of the right riser hook to pass through the tightest possible link of the chain.
3. Turn the tree step to a usable position. The two crossbars on the back of the riser will lock against the tree. When weight is put on the tree step, most of the stress is on these bars, which lock the step firmly against the tree.
4. Place the tree steps no more than 24 inches apart on the same side of the bole, or 12 inches from one step to the next when the steps are staggered on the bole. It is easier to place your feet when tree steps are staggered.
5. Use a safety harness and lanyard at all times when installing tree steps or when you are using them for support.

5.6.5 Care of Tree Steps

Tree steps require little care. Inspection for metal fatigue is the most critical maintenance requirement.

1. Inspect the metal platform, especially at all weld points or bends, such as at the riser hook and platform bend.
2. Inspect metal chain links individually for signs of metal fatigue or weld breakage.
3. Inspect the platform and the chain for signs of rust.
4. Store tree steps in a dry location.
5. Do not drop tree steps. Use a haul line when you need to transport tree steps to and from the live crown.
6. When signs of metal fatigue are evident on the platform portion of the tree steps, discard them immediately.
7. When the chain shows signs of metal fatigue, replace it with suitable 1/0 straight-link, welded coil chain.

6. Rappel Systems—Use and Care

Rappel systems make climbing and working in trees easier and safer. The four systems recommended in this guide should only be used below the 4-inch-bole-diameter level.

6.1 Rigging and Rappelling

Many different rappel devices are on the market, but not all are suitable for tree climbing applications.

1. Required characteristics of acceptable descending devices
 - A. Minimum breaking strength of 5,000 pounds
 - B. Adjustable friction control for different situations
 - C. Tie-off capability in work or rescue situations
 - D. Commercially designed and manufactured for intended use
2. Desired characteristics of acceptable descending devices
 - A. Suitable as the primary device in both work and rescue situations.
 - B. A variety of ropes can be used.
 - C. Adjustable friction control while under a load.
 - D. Difficult to rig or use incorrectly.
 - E. Device remains attached to the climber during rigging.

6.1.1 Recommended Uses of Rappel Systems

1. Working in branches below the 4-inch bole diameter, both adjacent to and away from the tree bole
2. Rappelling from live crowns
3. Rescuing a disabled climber
4. Lowering equipment or materials from the tree (not applicable with the Prusik rappel system)

6.1.2 Rigging Rappel Systems

Most of the recommended rappel systems may be rigged for either single- or double-rope rappel. The climber has the option of either:

- Looping the rope around the bole or through a tree-crotch lanyard below the 4-inch-bole-diameter level (both ends of the rope must reach the ground) and rappelling on both lengths of rope simultaneously

OR

- Attaching one end of the rope to a point in the tree below the 4-inch-bole-diameter level and rappelling on a single length of rope.

1. Deploying the rappel rope

When ascending a tree to rig a rappel system, three methods for deploying the rappel rope are:

- A. Ascend the tree in as straight a line as possible with the rappel rope attached to the safety harness. The rope is pulled from the storage bag on the ground as you ascend. With this method the ascent route will also be the descent route.
- B. Ascend the tree without regard to the route with a haul line in a storage bag attached to the safety harness. At the desired rigging point, lower the end of the haul line through the tree branches along the intended descent route. The ground person attaches the rappel rope to the end of the haul line, and you pull up the rappel rope with the haul line.
- C. Ascend the tree carrying the entire rappel rope in its storage bag. At the desired rigging point, secure the end of the rappel rope to the tree and drop the rope bag along the intended descent route. Occasionally, the rope and bag can get tangled or deflected by branches.

2. Rigging for a double-rope rappel

This is the most common means of rigging a rope for a rappel from a tree. This type of rigging allows you to descend to the ground and then retrieve the rappel rope. Two methods of rigging for a double-rope rappel are:

A. Standard method

- (1) Pass the running end of the rope around the tree bole and over one or two branches of a whorl at a secure point below the 4-inch-bole-diameter level. You only need to pass the rope over a couple of branches on the back side of the tree—avoid adding too much friction, which will make it difficult to retrieve the rope from the ground.

6. Rappel Systems—Use and Care

- (2) Tie a loop (with a figure eight on a bight) in the running end of the rope. This is not necessary with the Sky Genie system, which has a preformed loop in the end of the rappel rope.
- (3) Attach a carabiner to the figure-8 loop or preformed loop, and clip the carabiner onto the standing part of the rope.
- (4) Feed the loop and carabiner end down to the ground. The carabiner will follow the line already in place through the branches to the ground. The two lengths of rope will be used together during the rappel.
- (5) Feed the end of the rope to the ground. Provide a few extra feet of slack for attaching the rappel device when the carabiner touches the ground. Have the ground person verify that both ends of the rope reach the ground.
- (6) Attach the rappel device to both lengths of the rope as if they were one.
- (7) Follow the directions for attaching the rappel device to the safety harness and for proper use of the rappel device as described in sections 6.2 through 6.4.
- (8) To retrieve the rappel rope from the ground:
 - a. Remove the rappel device, untie any knots in the system, and remove the carabiner from the main line.
 - b. Pull on the longest of the two lengths of rope to retrieve the rappel rope from around the tree.
 - c. When the end of the rope reaches the rigging point in the tree, make sure the area around the tree is clear. Yell “ROPE,” and then pull the rope from the tree, taking care to avoid being hit by the falling rope.

B. Tree-crotch lanyard method

You may use a manufactured tree-crotch lanyard or cambium-saver device or you may use one that is constructed from a piece of webbing or rope that meets the 5,400-pound minimum breaking strength requirement.

- (1) When making a tree-crotch lanyard, select a length of suitable cordage that easily reaches around the tree at the attachment point. Use webbing sewn or tied into a loop, rope tied or spliced into a loop, or rope with loops tied or

spliced into each end. Homemade tree-crotch lanyards may hang up in the tree more easily because of the large knots in the cordage or improperly sized carabiners.

- (2) Construct the tree-crotch lanyard so that a knot will pass through one end of the lanyard, but not the other. This allows the ground person to pull both the lanyard and the rappel rope from the tree. Life-safety hardware should not be used to secure lanyards as the hardware will be subject to falls when it is pulled out of the tree. Use splices or knotted loops and rope thimbles to protect the rope or webbing from the sawing action of the rappel rope as it is pulled.
- (3) Clip the rappel rope through the snap end of the tree-crotch lanyard before hauling it into the tree. This ensures that the system will be set up correctly to remove it later from the ground.
- (4) Pass the tree-crotch lanyard around the tree bole at a secure point below the 4-inch-bole-diameter level and above a whorl of branches. You only need to pass the tree-crotch lanyard over a couple of branches on the back side of the tree. Avoid passing the tree-crotch lanyard over too many branches, which makes it hard to retrieve the rope and tree-crotch lanyard from the ground.
- (5) Pass the rappel rope through the snap catch and then through the carabiner or ring on the tree-crotch lanyard.
- (6) Tie a loop (with a figure eight on a bight) in the running end of the rope. This is not necessary with the Sky Genie, which has a preformed loop.
- (7) Attach a carabiner to the figure-8 loop or the preformed loop, and clip the carabiner back onto the main part of the rope.
- (8) Feed the loop and carabiner end back down toward the ground. The carabiner will follow the line already in place through the branches to ground level. The two lengths of rope will be used together during the rappel.
- (9) Feed the end of the rope to the ground. Provide a few extra feet of slack for attaching the rappel device once the carabiner touches the ground. Have the ground person verify that both ends of the rope reach the ground.

- (10) Attach the rappel device to both lengths of rope as if they were one (not applicable to the Prusik system).
- (11) Follow the directions for attaching the rappel device to the safety harness and for use of the rappel device as described in sections 6.2 through 6.4.
- (12) To retrieve the rappel rope from the ground:
 - a. Remove the rappel device, untie any knots in the main line, and remove the carabiner from the main line.
 - b. Tie a figure-8 knot in the end of the rope to be pulled through the tree-crotch lanyard. This is not necessary with the Sky Genie.
 - c. Pull on the rope so that the figure-8 knot is pulled up through the tree-crotch lanyard ring or carabiner.
 - d. When the end of the rope with the knot reaches the tree-crotch lanyard, clear the area around the tree and pull hard on the rope so the knot passes through the ring or carabiner of the tree-crotch lanyard. The knot should not pass through the snap catch end of the tree-crotch lanyard and should pull it from its rigging point.
 - e. **Take care to avoid being struck by the falling rope and tree-crotch lanyard.**
 - f. Occasionally, the tree-crotch lanyard remains stuck at its rigging point due to improper placement or improper rigging. If this happens, the tree must be climbed to retrieve the rope and lanyard. **Do not attach the rope to a vehicle and try to pull the rope from the tree. Doing so may damage the rope and lanyard.**

3. Rigging for a single-rope rappel

This method is NOT commonly used in tree climbing because it requires ascending the tree to retrieve the rope. However, this method is quick and can expedite a rescue descent.

To set up for this type of rappel, secure the upper end of the rope using a tensionless hitch (figure 6a).

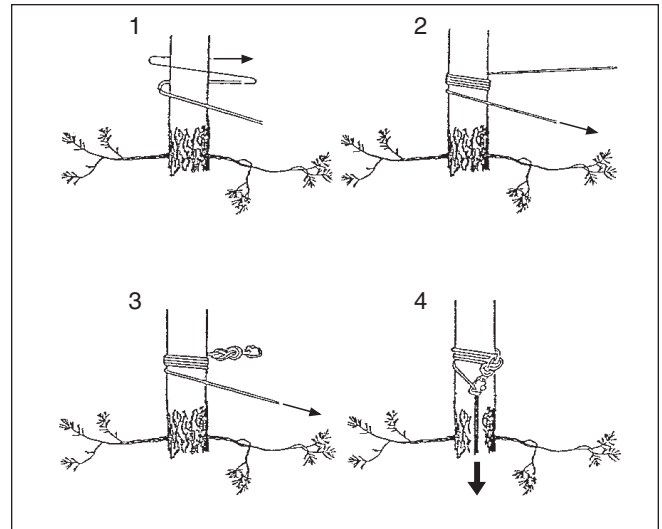

Figure 6a—Rigging a tensionless hitch for a rappel.

To retrieve the rappel rope, the tree must be climbed and the tensionless hitch untied. The tree must be descended by other means.

6.1.3 Rappelling

Rappelling means sliding down a rope in a controlled manner that prevents injury. Proper technique and attention to basic safety procedures are necessary.

1. Basic safety procedures for rappelling
 - A. Tie a figure-8 knot in the end (or ends) of the rappel rope to ensure that the climber does not rappel off the end of the rope.
 - B. With a double-rope rappel, make sure both lengths of rope weave through the branches together.
 - C. Ensure that the rappel device is properly rigged, attached to the harness, and tested with the climber's weight BEFORE releasing the lanyard.
 - D. Ensure that the rappel system is attached properly to the harness. Always attach the rappel system to the seat-sling portion of the safety harness. If the harness has two tie-in points, the system must be attached to both points with locking carabiners.
 - E. Provide for a bottom belay. The ground person provides the belay by holding the single- or double-rappel rope throughout the rappel. A fall can be arrested or stopped by applying downward pressure on the rappel rope. The climber's descent can be controlled by varying the pressure on the rappel rope.

6. Rappel Systems—Use and Care

- F. Never allow the rappel rope to rub against the safety harness webbing. Such rubbing can quickly melt synthetic webbing.
 - G. Keep beards, long hair, and loose clothing secured and away from the rappel device. Unsecured material can jam in the device, halting descent and causing pain, injury, or accidents.
 - H. Never use a knife while rappelling. Rope under tension cuts easily. If clothing or hair becomes lodged in the rappel device, an ascender or Prusik knot may be used to take pressure off the rappel device while dislodging the material. Use scissors to cut jammed material free. Exercise extreme caution to avoid cutting the rope or harness.
 - I. Before beginning to rappel, recheck all the rigging. Make sure that:
 - The rope is rigged properly.
 - The rope is threaded correctly on the rappel device.
 - The rappel device is attached correctly to the harness.
 - The system is tested with the climber's weight.
 - The carabiner gates are locked.
 - J. Wear sturdy gloves, such as heavy-duty leather gloves.
 - K. With the Prusik rappel system, maintain a load on the system at all times. The Prusik knot can quickly become loose if the working load is removed. If the load must be removed, place a lanyard around the tree or suitable branch and check the integrity of the Prusik knot before reapplying a load.
 - L. The rope wears more with the Prusik system than with other rappel systems. If a continuous loop is used (see figure 6p), check it often for signs of excessive wear.
2. Proper rappelling techniques
- A. Rappel at a moderately slow speed. Heat is generated by the friction of the rope against the rappel device. Excessive heat can damage the rope or burn exposed skin.
 - B. Rappel smoothly. Bouncing or a fast rappel with a sudden stop causes shock loadings that shorten rope life. Shock loads may cause an unrecognized weak anchor to fail or may lead to failure of other critical system components.
 - C. Assume a sitting position in the seat sling of the safety harness. Keep your legs nearly horizontal with your knees slightly bent. Keep your feet comfortably spread, if practical, to help prevent you from pivoting around the tree.
 - D. Always walk down the tree while rappelling, remaining in contact with the bole. This reduces loads and possible shocks on the entire rappel system.
 - E. Maintain the brake hand near your hip. Always keep the brake hand away from the rappel device except to lock off.
 - F. Create additional friction by wrapping the rappel rope under the buttocks and braking with the opposite hand. Take care not to run the rappel rope across the harness webbing.

6.2 Sky Genie

The Sky Genie variable descent system is a mechanical rappel device that can be used for many tree climbing tasks and rescue. The Sky Genie must be used only with the nylon rope that comes with the system.

6.2.1 Advantages of the Sky Genie

- Commonly available to tree climbers.
- Lighter and more compact than some devices.
- Operating principles are simple to comprehend.

6.2.2 Disadvantages of the Sky Genie

- The Sky Genie rope must be kept clean in order to work properly.
- The Sky Genie is relatively expensive.
- If the Sky Genie's cover is lost, the system will not function.
- The Sky Genie lacks a wide, continuous range of friction. It cannot be adjusted during a rappel.
- The Sky Genie can only be used on the rope that comes with the system.
- Jammed hair or clothing can be drawn into the Sky Genie where it cannot be easily removed.

- The Sky Genie must be detached from the safety harness during rigging.

6.2.3 Procedures for Using the Sky Genie

1. Rigging the Sky Genie

The procedure for rigging the Sky Genie is essentially the same for either a double-rope or single-rope rappel (figure 6b).

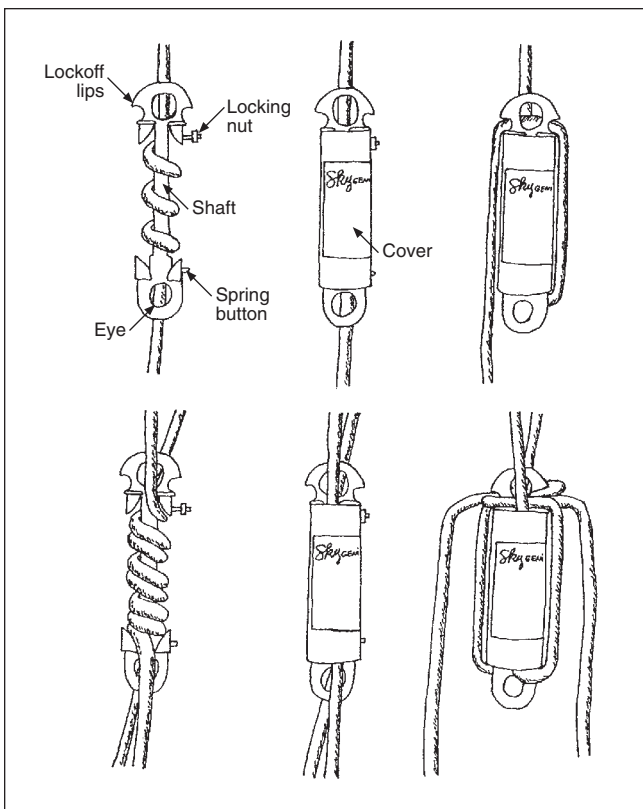

Figure 6b—Single-rope rigging (top) and double-rope rigging (bottom) for the Sky Genie.

- Loosen the locking nut at the upper end of the Sky Genie cover. While holding the top eye of the Sky Genie, press the spring button at the lower end of the cover to slide the cover off the shaft.
- Place the cover inside your shirt or some other secure location. Without the cover, the system will not work.
- Place the rappel rope in the slot at the top of the Sky Genie shaft. If you are rigging for a double-rope rappel, place the two lines in separate slots.

- Begin wrapping the rappel rope(s) around the shaft. An arrow located near the locking nut at the upper end of the shaft indicates the direction the rope should be wrapped.
- The number of wraps depends on the amount of weight to be controlled. Descent Control, Inc. (the manufacturer) recommends five wraps for the first 150 to 200 pounds of load with one additional wrap for each additional 50 pounds over 200 pounds. The number of wraps is counted along the shaft axis between the locking nut and the spring button. A wrap is counted each time the rope passes the axis. When rigged for a double-rope rappel, each line is counted as a wrap when it passes the axis (four turns with a single rope produces about the same amount of friction as two turns with a double rope).
- After completing the desired number of wraps, place the rope(s) in the slots at the bottom of the Sky Genie shaft. The rope(s) must remain in these slots when you replace the cover to keep the rope from being pinched.
- While holding the wrapped shaft, slide the cover over the rope(s) and shaft. The slot in the back of the cover is for passing the rope to the inside of the cover.
- Ensure that the spring button is positioned in the small hole on the cover. Gently secure the locking nut finger-tight only. Never overtighten this nut.
- Secure the rigged Sky Genie to the safety harness attachment point(s) with a locking carabiner through the eye at the bottom of the Sky Genie.
- The amount of braking force depends on the amount of downward tension applied to the rope coming out of the Sky Genie and the amount of contact between the rope and the climber's body.

- Before beginning to rappel, recheck all the rigging. Make sure that:
 - The rope is rigged properly.
 - The rope is threaded properly on the Sky Genie.
 - The Sky Genie is attached correctly to the harness.
 - The system is tested with the climber's weight.
 - The carabiner gates are locked.
- Increasing friction when using the Sky Genie

Any combination of the following actions increases the braking force for a given number of wraps around the Sky Genie shaft:

6. Rappel Systems—Use and Care

- A. Gripping more tightly with the braking hand (gloves help prevent discomfort or friction burns).
- B. Lifting the running part of the rope above the Sky Genie device. The running part of the rope should be used only as a brake and not as the sole means of creating friction throughout the rappel.
- C. Holding the rope firmly against your body.
- D. Wrapping the rope around part of your body (a leg or your buttocks).

More friction can be generated by increasing the number of wraps around the Sky Genie shaft (figure 6b).

Pay close attention to how the rope runs across the harness webbing. The friction generated can damage the harness or cause it to fail.

4. Reducing friction when using the Sky Genie

Any combination of the following actions reduces the braking force:

- A. Unwrapping the rope from around any part of your body
- B. Holding the rope away from your body
- C. Loosening the grip of the braking hand
- D. Placing fewer wraps around the Sky Genie shaft

5. Locking off the Sky Genie

- A. Stop the rappel with the braking hand about a foot from the Sky Genie by grasping the rope firmly with the braking hand.
- B. While holding the rope tightly in the braking hand, bring the rope up in a smooth arc and hold it against the Sky Genie cover. Wrap the free hand around the cover and rope. This traps the rope against the cover, preventing the rope from slipping.
- C. Loop the standing part of the rope over the top of the Sky Genie and trap the rope firmly between the top of the Sky Genie and the taut rope extending from the rigging point. Ensure that the rope is secured under the lockoff lips at the top of the Sky Genie. If the Sky Genie is rigged for a double-rope rappel, both lines must be locked off in this manner.
- D. If you will be moving around with your hands off the rope while you are tied off, further secure the lockoff by tying an overhand knot or two half-hitches around the standing part of the rope with a bight from the running part of the rope.
- E. To resume the rappel, untie the overhand knot or two half-hitches and grip the shell and the rope with your free hand, trapping the rope against the cover.

With the braking hand, remove the loop(s) of rope from the lockoff lips at the top of the Sky Genie.

- F. Maintain secure control of the running end of the rope at all times. Hold the rope firmly with the braking hand underneath the standing part of the rope. Then pull the rope in a smooth, continuous arc back into the rappel position.

6.2.4 Care of Sky Genie System

1. Carefully clean and coil the rope back into the rope bag. Store all the components in the bag that comes with the Sky Genie or in another suitable container.
2. Check the Sky Genie and accessories for metal fatigue and excessive shaft and rope wear before use each day.
3. Remove burrs and nicks on the cover and shaft that may accelerate rope wear.
4. Remove dirt and pitch, as needed, so equipment functions properly. To clean off pitch:
 - A. Remove pitch with hand cleaner.
 - B. Chainstitch or coil and tie the rope to prevent tangles.
 - C. Wash the rope in a front-loading machine using mild soap and warm water (no warmer than 120 °F).
 - D. Spin the rope dry in the washer. **Never use a heated dryer.**
 - E. Uncoil the rope and hang it in the shade to dry.

6.3 Figure-8 Descenders

The figure-8 descender is a mechanical friction device suitable for tree climbing tasks, such as descending and lowering.

Use the rescue-style figure-8 descenders with “ears” for tree climbing rescue applications (figure 6c). The ears prevent rope inversions and provide a more secure tie off. The larger size ensures maximum strength, adaptability to various rope configurations, maximum heat dissipation, and suitability for rescue use.

Figure-8 descenders are available in aluminum and steel. Aluminum descenders are lighter, provide more friction on the rope, and are more easily damaged when dropped. Steel descenders are heavier, the rope slides through them more easily, and they are less easily damaged.

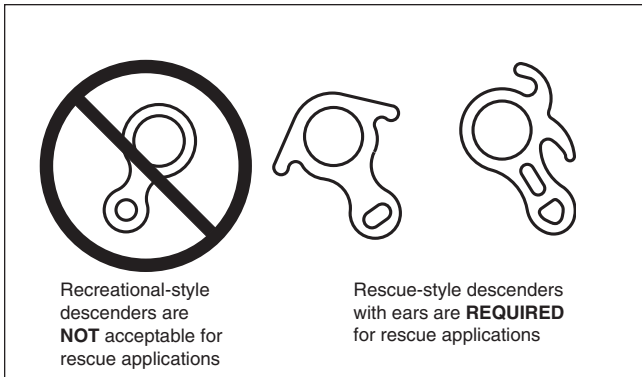

Figure 6c—Figure-8 descenders.

6.3.1 Advantages of Figure-8 Descenders

- Lightest and smallest rappel device suitable for tree climbing work.
- May be used on most kernmantle ropes suitable for life support.
- Difficult to rig improperly.
- Relatively simple to operate.
- Least-expensive mechanical rappel device suitable for tree climbing.
- Most climbers are familiar with their use.
- Rescue-8 style with top-mounted ears handles doubled rope applications well.
- Recreational-8 style can be utilized in secured footlock climbing to allow safe descent capability.
- Rescue-8 style with side-mounted ears offers ability to vary friction while in use. Works especially well with single ropes.

6.3.2 Disadvantages of Figure-8 Descenders

- They do not allow friction to be varied greatly.
- With the exception of the Rescue-8 style with side-mounted ears, friction cannot be varied significantly while under load.
- With the exception of the Rescue-8 style with side-mounted ears, lockoff procedures can be somewhat difficult.
- They may not provide enough friction with some ropes or for some uses.

- They can twist and kink some types of ropes.
- The exposed friction mechanism can entrap loose clothing or long hair.
- Care must be exercised to avoid over-heating smaller units such as the recreational-8 style.
- Rescue-8 style with side-mounted ears may be awkward to operate unless mounted with ears oriented toward the rappeler's braking hand.

6.3.3 Procedures for Using Figure-8 Descenders

1. Rigging the figure-8 descender.
 - A. Hold the figure-8 descender with the larger hole away from the climber.
 - B. Form a bight in the running part of the rope on the same side as the braking hand. Feed the bight through the large hole of the figure-8 descender from top to bottom.
 - C. Pull the bight up over the small end of the figure-8 descender so the bight rides across the top of the waist of the descender.
 - D. Take up any slack in the rope and use locking carabiners to attach the descender's small hole to the climbing harness.
 - E. Looking down at the figure-8 descender, feed the standing part of the rope down through the large hole, pass it around and over the top of the waist of the figure-8 descender, and back up through the large hole to become the running part of the rope (figure 6d). The running part of the rope should come out of the large hole on the same side as the braking hand (normally the dominant hand).

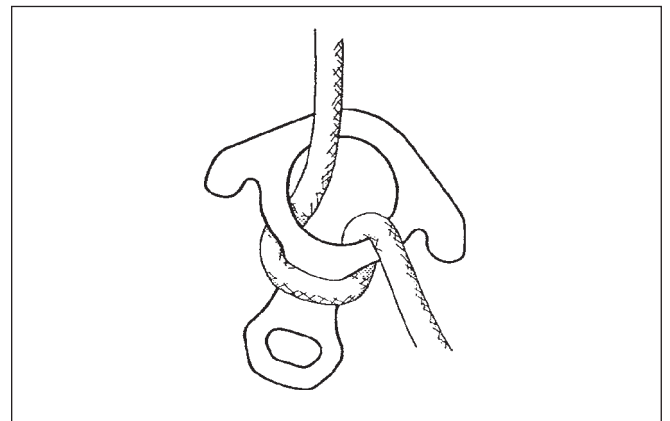

Figure 6d—A rigged figure-8 descender.

6. Rappel Systems—Use and Care

- F. The amount of braking force depends on the angle of the rope coming out of the figure-8 descender and the amount of rope in contact with the climber's body. The most friction is created by wrapping the rope under your buttocks and braking with the opposite hand. The least friction is created by holding the rope straight up after it leaves the figure-8 descender.
2. Before beginning to rappel, recheck all the rigging. Make sure that:
- The rope is rigged properly.
 - The rope is threaded properly on the figure-8 descender.
 - The figure-8 descender is attached correctly to the harness.
 - The system is tested with the climber's weight.
 - The carabiner gates are locked.
 - A bottom belay is provided by the ground person.
3. Increasing friction when using figure-8 descenders.
- Any combination of the following actions increases the braking force:
- A. Holding the rope firmly against your body.
 - B. Wrapping the rope around your leg or buttocks.
 - C. Gripping more tightly with the braking hand. (Gloves must be worn to prevent friction burns.)
 - D. Wrapping the rope over the top side-mounted ear.
- A rappel on a single rope will not generate as much friction through the figure-8 descender as a rappel on a double rope.
- Considerably more friction can be generated by wrapping the bight through the large hole and over the small end twice.
- Prevent the rope from running across the harness webbing. The friction the rope generates can damage the harness or cause it to fail.
4. Reducing friction when using figure-8 descenders.
- Any combination of the following actions reduces the braking force:
- A. Unwrapping the rope from around any part of your body.
 - B. Holding the rope away from your body.
 - C. Loosening the grip of the braking hand.
 - D. Lifting the running part of the rope toward or above the figure-8 descender.
 - E. Unwrapping the rope from over the top side-mounted ear.
5. Locking off figure-8 descenders.
- A. Stop the rappel by grasping the rope firmly with the brake hand within a foot of the figure-8 descender.
 - B. Holding the rope tightly with the braking hand, grasp the small end of the figure-8 descender with the free hand to prevent the rope from twisting out of position during the next step. QUICKLY bring the running part of the rope up in a smooth continuous motion and pass it between the standing part of the rope and the top of the figure-8 descender. When using the Rescue-8 with side-mounted ears style descender, wrap one complete turn around both side-mounted ears prior to passing the running part of the rope between the standing part of the rope and the top of the figure-8 descender. This wrap secures the device, preventing loss of braking action while completing lockoff procedures.
 - C. Pull the running end of the rope down firmly toward you until it securely wedges into position (figure 6e). Take this step without hesitation because the braking action of the device is reduced as you bring the running part of the rope up toward the figure-8 descender. When using the Rescue-8 with side-mounted ears style descender, if the running part of the rope is fully wrapped around both side-mounted ears, this step occurs in a controlled manner. No reduction in braking action occurs as you bring the running part of the rope up toward the descender.
 - D. Continue to secure the lockoff by bringing the running end below the ears and underneath the waist of the figure-8 descender. Wrap the running end of the rope around the descender two or three times (figures 6f and 6g).
 - E. If you will be moving around with your hands off the rope while you are tied off in the tree, further secure the lockoff by tying an overhand knot or two half-hitches around the standing end of the rope with a bight from the running part of the rope (figure 6h).
 - F. To resume rappelling, reverse the lockoff procedure, but do not remove the final wrap of rope that is wedged between the standing part of the rope and the figure-8 descender.
 - G. Maintain secure control of the running end of the rope at all times. Hold the rope firmly with the braking hand underneath the standing part of the rope. With the braking hand, pull the rope in a smooth, continuous arc back into the rappel

position. There will be a slightly audible “pop” and a slight bump as the rope unlocks from the rappel device. When using the Rescue-8 with side-mounted ears style descender, control of braking action is improved by the full wrap around both side-mounted ears. Gradual reduction of friction is attained by gradual removal of this wrap after pulling the rope back into the rappel position.

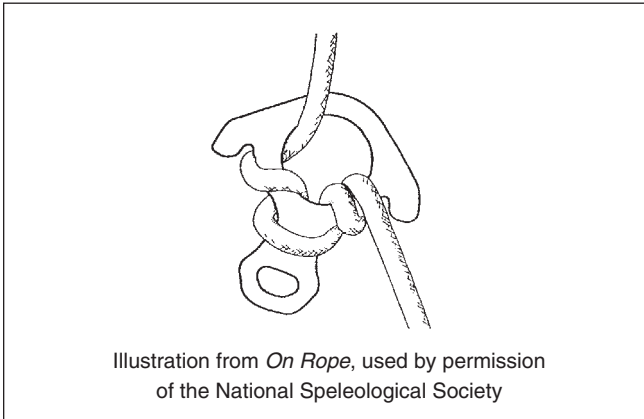

Figure 6e—Locking off the figure-8 descender—first bind.

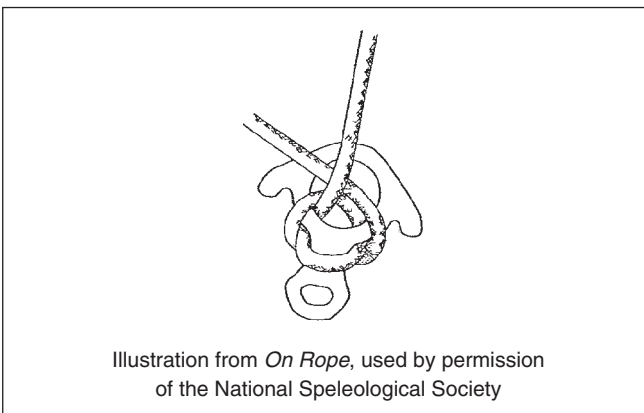

Figure 6f—Locking off the figure-8 descender—second bind.

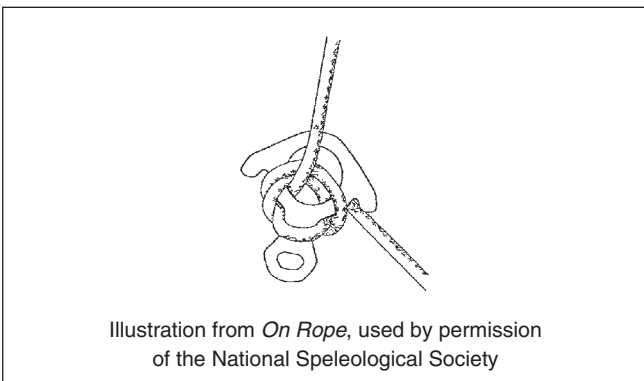

Figure 6g—Locking off the figure-8 descender—lockoff complete.

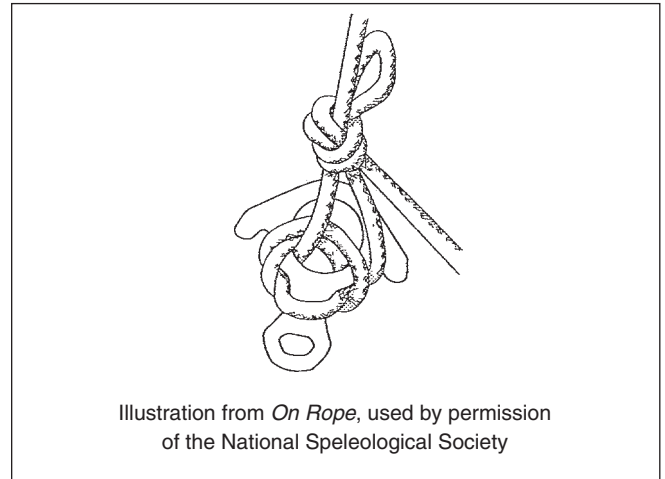

Figure 6h—Locking off the figure-8 descender—lockoff secured.

6.3.4 Care of Figure-8 Descenders

The figure-8 descender is a simple, durable piece of equipment that requires little special care.

1. Carefully inspect each figure-8 descender before each use, both by looking it over and by feeling for irregularities:
 - A. Inspect for cracks, accumulations of pitch, and other defects and debris.
 - B. Carefully feel the entire surface of the figure-8 descender for corrosion, burrs, or edges that would cause unusual rope wear.
2. Smooth any wear points with a fine abrasive.
3. Remove pitch using any effective cleaner.
4. Equipment that shows evidence of cracks, corrosion, extreme wear, or other physical defects should be removed from service immediately.
5. The figure-8 descender should never be dropped from heights, used as a hammer, or subjected to other physical abuse.

6.4 Rappel Rack

The rappel rack is a mechanical, variable-friction device suitable for most tree climbing tasks, such as descending and lowering (figure 6i). The rappel rack is the preferred descent device for rescues because it allows the rescuer to vary the friction while the rescuer is rigged during a rappel.

6. Rappel Systems—Use and Care

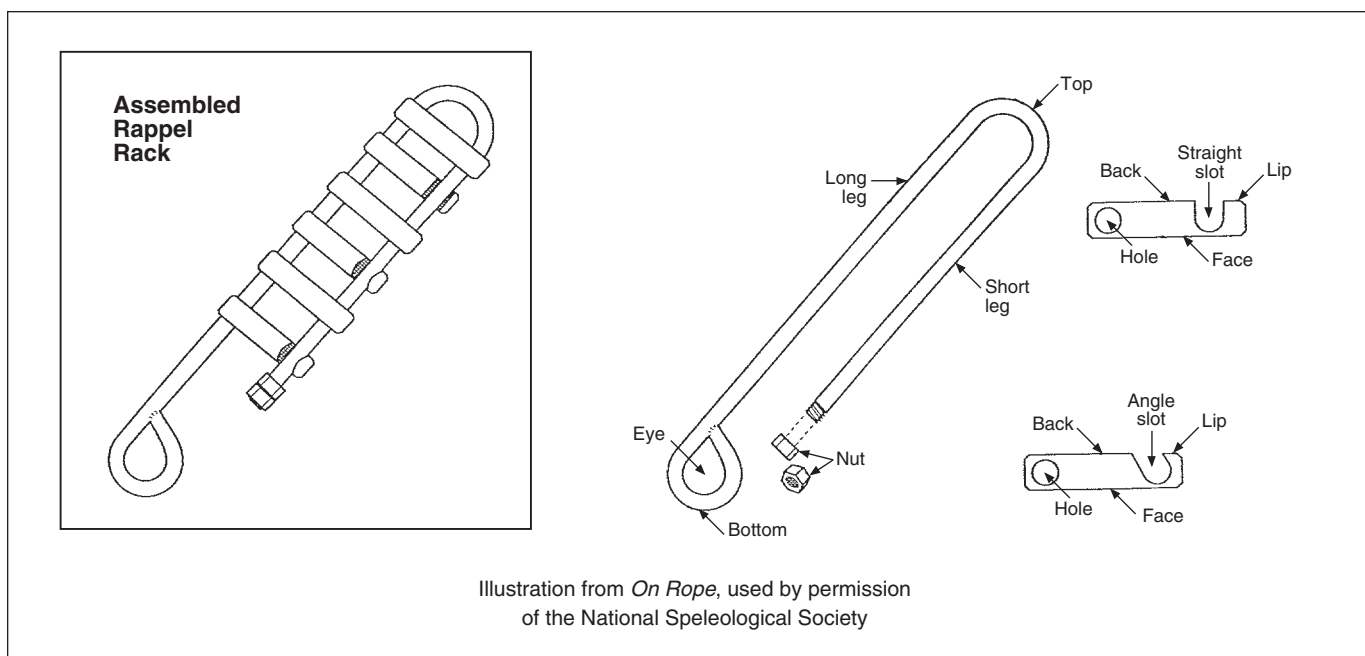

Figure 6i—A rappel rack.

Six-bar rappel racks should be used for tree climbing. All six bars should remain installed on the frame to allow immediate application for rescue situations. The second bar should have a straight slot to prevent incorrect rigging. Racks with welded eyes are recommended to ensure maximum strength. Some racks that are specially made for rescue do not have an “eye,” but are rigged to attach to the rappeller at the U-end and have a large tie-off brake bar at the other end.

6.4.1 Advantages of Rappel Racks

- Allow continuously variable friction adjustment while the climber is under a load. Variable friction adjustment allows greater control and makes rappelling easier when ropes are contaminated with dirt or pitch, when lowering loads, or during a rescue.
- May be used on any rope suitable for life support.
- Can provide more friction than some other devices.
- Difficult to rig improperly when the proper bar configuration is installed (a straight slot is required on the second bar).
- Less expensive than some other devices.
- Remain attached to the harness during rigging.

6.4.2 Disadvantages of Rappel Racks

- Must be properly assembled by the purchaser before use for safe, efficient operation.
- More complex to rig and use than some other devices.
- More bulky and awkward when not being used than most other devices.
- The exposed friction mechanism can entrap loose clothing or long hair.

6.4.3 Procedures for Using Rappel Racks

1. Correct rack assembly is critical for safe use.
 - A. Position the brake bars on the frame so the bar ends with the holes are on the long leg of the frame (the leg containing the attachment eye). Bar slots must face in alternate directions (figure 6j). Some sources suggest alternating the holes from one side to the other.
 - B. If the rope does not contact the side of the bars opposite the slot opening, tension on the rope during the rappel will disengage the bars from the rack. The second bar from the top of the frame should have a straight slot to make improper rigging immediately obvious. Failure to use at least

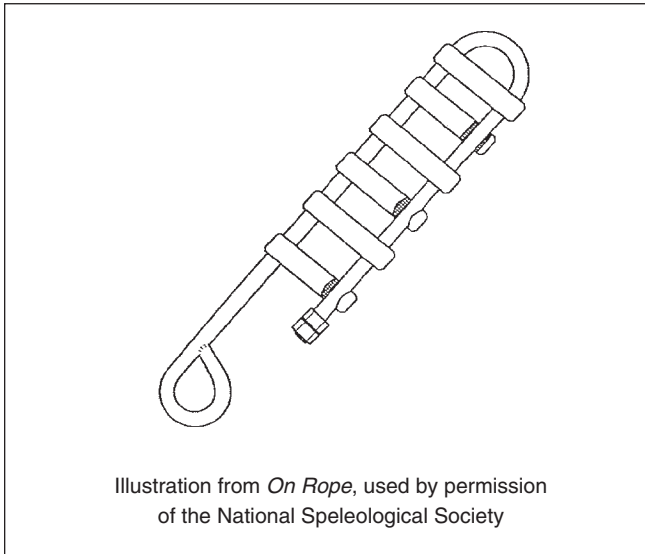

Figure 6j—A correctly assembled rappel rack.

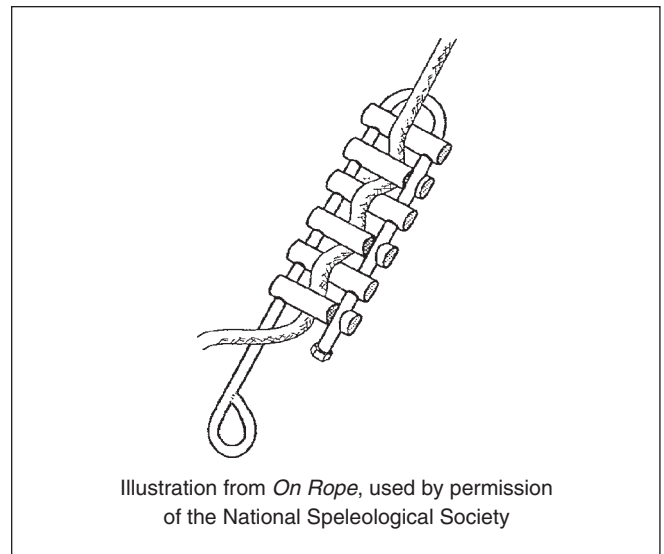

Figure 6k—A correctly rigged rappel rack.

one straight-slot bar makes it more difficult to recognize an improperly rigged rack. This may not be apparent until the climber is in an exposed position.

- C. The short leg of the frame must have either a secure locking nut or two nuts firmly tightened together to ensure that bars remain on the frame during use.
 - D. If the legs of the frame will be parallel to the climber's waistbelt, the short leg should be on the same side as the braking hand. If the legs of the frame will be perpendicular to the climber's waistbelt, the short leg may be up for greatest security or down to make it easier to engage and disengage bars.
2. Rigging rappel racks.
 - A. Attach the rack to the seat harness. Disengage the slotted ends of all but the top bar from the short leg of the frame. Pass the rope between the legs of the frame so it touches the solid side of the top bar. The rope is NOT passed between the top bar and the bend of the frame because doing so would pinch the rope.
 - B. Engage the second bar and slide it up temporarily, pinching the rope between the top and second bar. Pass the rope back between the legs of the frame and engage the third bar. Continue this process until all bars are engaged (figure 6k).

- C. Before beginning to rappel, recheck all the rigging to make sure that:
 - The rope is properly rigged.
 - The rope is threaded on the correct side of each bar.
 - The rack is attached correctly to the harness and has been tested with the climber's weight.
 - The carabiner gates are locked.

3. Increasing friction when using rappel racks.

Any combination of the following actions will increase the braking force:

- A. Pushing the bars toward the top of the rack with the guide hand.
- B. Pressing the rope against or around your leg or buttocks with the braking hand.
- C. Applying tension to the rope by gripping the rope more firmly with the braking hand (gloves must be worn to prevent friction burns).
- D. Raising the running part of the rope with the braking hand to press the bars together.
- E. Engaging additional bars.

6. Rappel Systems—Use and Care

4. Reducing friction when using rappel racks.

Any combination of the following actions will reduce the braking force:

- A. Pulling the bars toward the bottom of the rack.
- B. Moving the rope away from your body with the braking hand.
- C. Gripping the rope less firmly with the braking hand. In cases of excessive friction or light load, it may be necessary to actually push the rope into the rack.
- D. Disengaging the bars.

5. Locking off the rappel racks.

- A. Stop the rappel by pushing the bars up toward the top of the rack with the guide hand and bringing the rope in the braking hand toward the top of the rack.
- B. Lock off the rack by keeping the running end of the rope taut and slipping it between the standing part of the rope and the top of the rack (figure 6l). Do not allow the rope to become pinched between the rack and the standing part of the rope below the first brake bar.

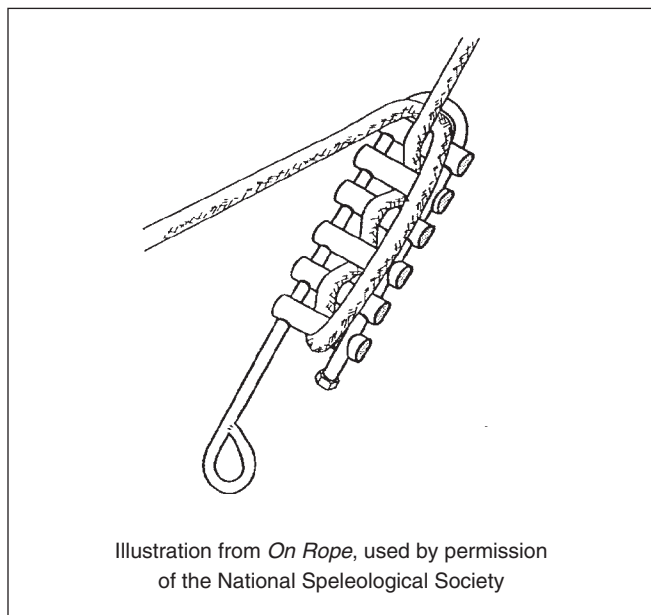

Figure 6l—Locking off the rappel rack—first bind.

- C. Secure the lockoff by bringing the running end of the rope back down between the legs of the rappel rack frame (first wrap) and under the bottom bar, up behind the rack, and between the rack and

the standing part of the rope (figure 6m). When rappelling on a double rope, normally the second wrap cannot be made because of the large amount of rope and the small space at the top of the rack. If you are using a double rope, make one wrap over the top of the frame and bring the running part back down between the legs, under the bottom bar, and up behind the rack. Secure the rope by tying an overhand knot or two half-hitches as described in paragraph D below.

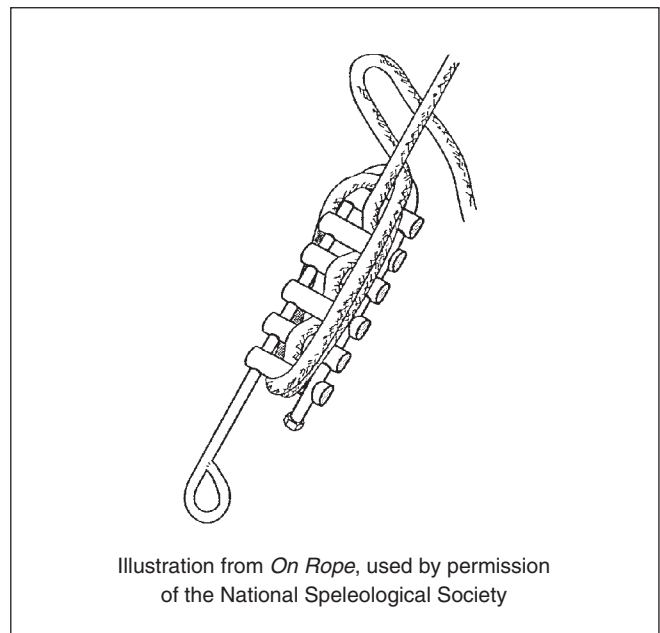

Figure 6m—Locking off the rappel rack—second bind.

- D. If you will be moving around with your hands off the rope while you are tied off, further secure the lockoff by tying an overhand knot or two half-hitches around the standing part of the rope with a bight from the running part of the rope (figure 6n).
- E. To resume rappelling, reverse the lockoff procedure. There may be a slight bump as the rope unlocks from between the standing part off the rope and the top of the rack. Press the bars up with the guide hand until the braking hand has returned to the rappel position.

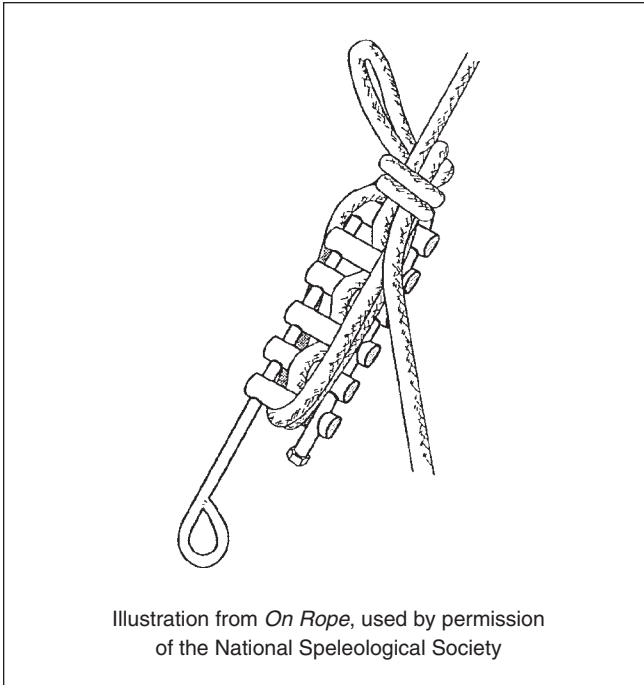

Figure 6n—Locking off the rappel rack—lockoff secured.

6.4.4 Care of Rappel Racks

1. Inspect the frame.
 - A. No corrosion, burrs, or rough edges should be present.
 - B. Both legs should be straight, parallel, and in the same plane.
2. Inspect the bars.
 - A. No corrosion, burrs, or rough edges should be present.
 - B. No cracks or deformities should be present.
3. Inspect the assembly.
 - A. Bars should be in the correct order and positioned with holes on the long leg of the frame.
 - B. Lock nut(s) on the short leg should be secure.
 - C. Bars should slide freely on the frame.
 - D. All components should be free from accumulations of pitch.
4. Maintenance and repair of rappel racks.
 - A. Smooth off surface corrosion, burrs, and rough edges with a fine abrasive. The frame may be bent BY HAND to correct minor irregularities. Remove pitch with any effective cleaner.
 - B. Remove from service any bars that are deeply worn or deformed and frames that cannot be straightened by hand. Replace deeply corroded components.
 - C. The rappel rack should never be dropped from heights, used as a pry bar, or subjected to other physical abuse.

6.5 Prusik System

The Prusik system is widely used by arborists and can be used effectively in tree improvement work. Make sure that the Prusik knot will work properly on a new rope. Always break in a new rope before use by running the rope through the Prusik knot until the knot grabs when under tension.

6.5.1 Advantages of the Prusik System

- Easily adjustable
- Climber can rappel with no devices other than a rope and a Prusik loop

6.5.2 Disadvantages of the Prusik System

- On some ropes, the Prusik knot will not tighten properly.
- The Prusik knot may fail if tied incorrectly.
- Rope abrasion and friction can damage trees, particularly thin-barked species, as well as the rope itself. The Prusik system can also cause excessive wear to the rope and will shorten its life.

6.5.3 Procedures for Using the Prusik System

1. Place the climbing line around the bole and above one or two branches or a whorl of branches as shown in figures 6o and 6p.

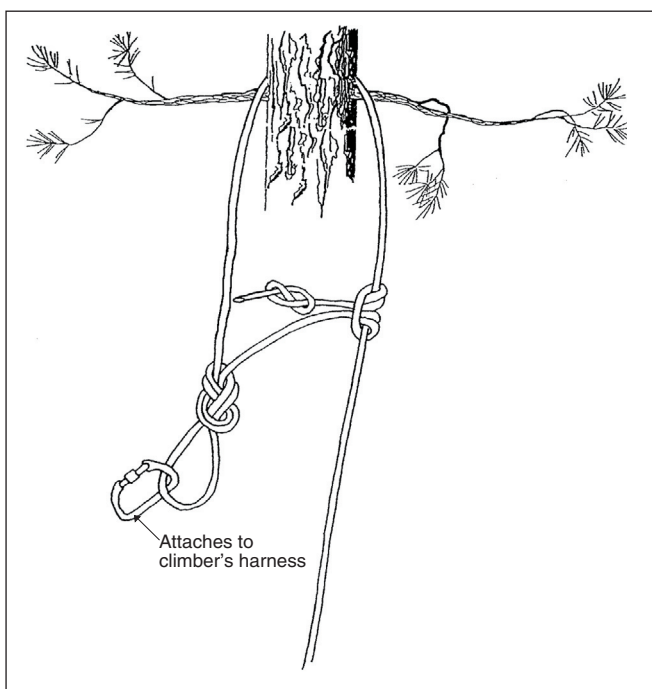

Figure 6o—Rigging the Prusik system, standard method.

- A. Right-handed climbers pass the end of the climbing line around the tree from right to left; left-handed climbers pass it from left to right.
 - B. Select a stout whorl of branches that can withstand the abrasion of the Prusik rappel system and hold your weight and the weight of your equipment during the descent. The climbing line only needs to be passed over one or two branches, not the entire whorl. Excessive friction at this point will impede or prevent your descent and retrieval of the rope.
2. Make sure there is enough climbing line to reach the ground or a safe rigging point. You will need slightly more than twice as much climbing line as the height of the rigging point to the ground.

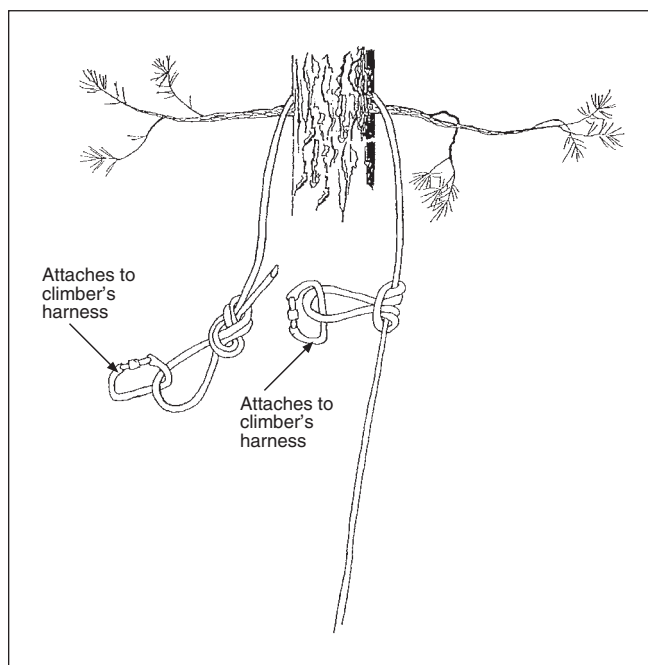

Figure 6p—Rigging the Prusik system, continuous loop method.

3. Rig the Prusik rappel system using the standard or the continuous loop method.
 - A. Standard method for rigging the Prusik system
 - (1) Using the running end of the mainline, tie a Prusik knot or Blake's hitch on the climbing line and secure the running end with a figure-8 knot within 2 to 4 inches of the Prusik knot (figure 6o).
 - (2) Check the Prusik knot to be sure that it provides adequate friction. Check the figure-8 knot to ensure that it is positioned correctly and tied securely.
 - (3) Tie a figure eight on a bight with the length of rope used to form the Prusik knot. This loop should be formed close enough to the Prusik knot to permit the climber to reach the knot easily during a rappel.
 - (4) Use locking carabiners to secure the figure-8 loop to the seat sling tie-in point of the safety harness. Make sure the carabiners are locked.

- B. Continuous loop method for rigging the Prusik system
- (1) Use rope to form a continuous loop with at least a 5,400-pound breaking strength (see section 8.4). The loop should be made from rope that is the same diameter or slightly smaller than the climbing line and that is about as stiff or slightly softer than the climbing line.
 - (2) Pass the climbing line around the tree, and secure the end of the rope to the seat sling tie-in point(s) on the safety harness.
 - (3) Tie the continuous loop into a Prusik knot on the climbing line as shown in figure 6p. Use a locking carabiner to secure the loop to the seat sling tie-in point(s) on the safety harness. **NOTE:** If the climbing harness has two tie-in points (for example, the Sky Genie harness), you must secure both the climbing line and the Prusik loop to each tie-in point.
4. Before rappelling, check that:
- A. All the knots are properly tied, dressed, and set.
 - B. The system is securely attached to the seat sling tie-in point of the safety harness, and the carabiner gates are locked.
 - C. The Prusik knot or Blake's hitch is properly tied and tightened. A loose Prusik knot can cause the system to fail. When the system is rigged with the standard method, the Prusik-knot's tail must be tied off with a figure-8 knot to prevent the knot from coming loose.
 - D. Personal safety equipment is in place. The safety helmet chinstrap should be secured. Gloves should be on and adjusted. The safety harness should be properly secured and adjusted. Loose clothing, long hair, jewelry, and facial hair should be kept clear of the Prusik knot.
 - E. The descent route is free of potential hazards.
 - F. A figure-8 knot has been tied at the end of the climbing line to prevent the climber from accidentally rappelling off the end of the line.
5. To descend, pull on the top of the Prusik knot. The descent should be moderately slow and smooth to avoid unnecessary stress on the rope. Fast descents generate excessive heat that can damage the rope. Bouncy or jerky descents place shock loads on the rope that will shorten its life.
 6. **To stop, let go of the knot.** If the knot fails to function properly and you are unable to stop, pull on the short section of rope from the top wraps of the Prusik knot. Pulling on this piece of rope tightens the knot, providing additional friction.
 7. After completing work in the live crown, you may continue to rappel to the ground.
 8. Untie the Prusik system only when you are on the ground or when you are secured with a lanyard in the tree.
 9. Ensure that the Prusik knot does not come loose at any time. Releasing tension on the system may allow the Prusik knot to loosen, resulting in a fast, uncontrolled descent. Recheck the Prusik knot before resuming descent.
 10. Numerous long descents on kernmantle rope may stretch the woven outer sheath. This will cause the sheath to bunch up below the Prusik knot, preventing further descent. On kernmantle rope, the Prusik system should be used for short descents or as a safety system while working in the tree. A mechanical descender should be used for long rappels from the tree.
 11. To remove the Prusik system from the tree, untie all the knots and pull the climbing rope from around the tree. Keep clear of the falling rope.

6.5.4 Care of the Prusik System

Check the integrity of all the knots and splices in the system before and after each use. Ropes should be checked for wear according to section 3.1.6.

6. Rappel Systems—Use and Care—Notes

7. Rescue

The basic tree climbing team is composed of two persons, so both team members must be certified climbers qualified to perform the climbing assignment. All certified climbers should be equipped and trained to render emergency care if a climber becomes incapacitated while in a tree. Training includes first aid and techniques to secure an injured climber in a comfortable position in the tree or to remove a climber from the tree.

Rescues should be accomplished using standard, familiar equipment, not “special” gear designed solely for rescue. Climbing teams should develop and practice rescue techniques with the equipment that will be used. Before a climb, members of the team should discuss the various climbing and rescue procedures that may be needed for that assignment.

Climbing teams should be prepared for potential problems on any assignment. They should sign out with the local unit and carry portable radios. Climbers should also be aware of other climbing teams in the area and their general location.

When climbers reach their climbing area, they should test their radios before beginning a climb. A portable radio should be kept at the tree. Climbers should note the legal description of their work area, as well as detailed access information, so they can provide accurate directions in an emergency. If immediate contact with the local unit or dispatch office cannot be established from the job site, a contingency plan should be developed to summon emergency help, or the climb at that job site shall be abandoned.

During a rescue, the potential for suspension trauma should be considered. Suspension trauma can occur when a person is suspended vertically, such as from the chest or back D-ring attachment point of a fall protection harness. Blood begins to pool in the legs and the heart must work harder to pump blood to the brain. If the heart cannot keep up, it will slow down, leading to a loss of consciousness. Death can occur in as little as 5 minutes. If a victim is suspended vertically and unable to correct the situation, the rescuer needs to reach the victim and correct their position as quickly as practical. Simply bending the legs at the knees to form a sitting position will solve the problem. If the victim is unconscious, do not immediately move the victim to a horizontal (prone) position. If suspension trauma is occurring, the sudden flow of blood to the brain can be fatal.

7.1 Rescue Equipment

Equipment needed to aid an incapacitated climber in a tree consists of the basic equipment described in section 2.1, plus additional rescue and first-aid items.

Place rescue equipment in a pack reserved for rescue purposes only. Plainly mark the pack for this use. List the pack’s contents on a tag or include a contents list inside the pack. Before each assignment, make sure all the items are in the pack and that they are in good condition. This rescue gear must be readily available during all climbing operations.

7.1.1 Recommended Items for the Rescue Pack

1. One 10-unit (minimum) first-aid kit that includes a body-fluid barrier kit.
2. Flashlight and extra batteries.
3. Roll of brightly colored flagging.
4. Waterproof matches.
5. Two blankets sealed in plastic. These can be used for treating shock or for splinting.
6. Backboard (collapsible, if available).
7. Long and short splints (in addition to those that may be in the first-aid kit).
8. Cervical collars (two adjustable collars or a range of sizes). These are to be used only by trained personnel.
9. Eye wash or a bottle of sterile water to wash out the eyes (in addition to materials that may be in the first-aid kit).
10. Two rescue pulleys (minimum).
11. Four locking carabiners (minimum).
12. Several 10- to 12-foot lengths of webbing or rope, plus 50 feet of 1-inch tubular webbing or static 11-millimeter rope (see NFPA 1983 for suggested color coding).
13. Heavy-duty metal shears or a small hacksaw for cutting jammed carabiners or steel-core lanyards.
14. A rope suitable for rescue, if such a rope is not included with basic climbing equipment (see section 2.1).

7.1.2 Constructing a Body Harness

Climbers should wear a climbing harness designed to provide support to both the chest and pelvis on ALL CLIMBING ASSIGNMENTS. If this harness is damaged in a fall, a rescue harness will need to be constructed and fitted to the victim.

For instructions on constructing a body harness, refer to page 30 of *Ropes, Knots, and Slings for Climbers* (Wheelock

7. Rescue

1967). The body harness may also be constructed as shown in figures 7a and 7b. The diaper sling can be constructed from about 12 feet of nylon webbing or nylon rope. Use a water knot to secure webbing or the grapevine knot or figure-8 bend to secure a rope. Secure all knots with overhand knots.

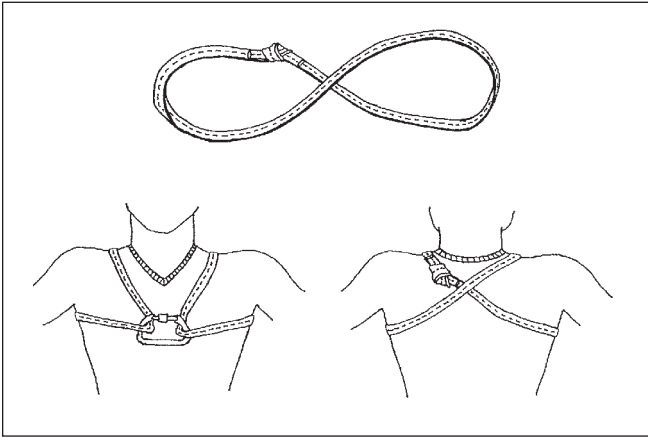

Figure 7a—Constructing the chest harness. Tails should be long enough to tie off with an overhand knot.

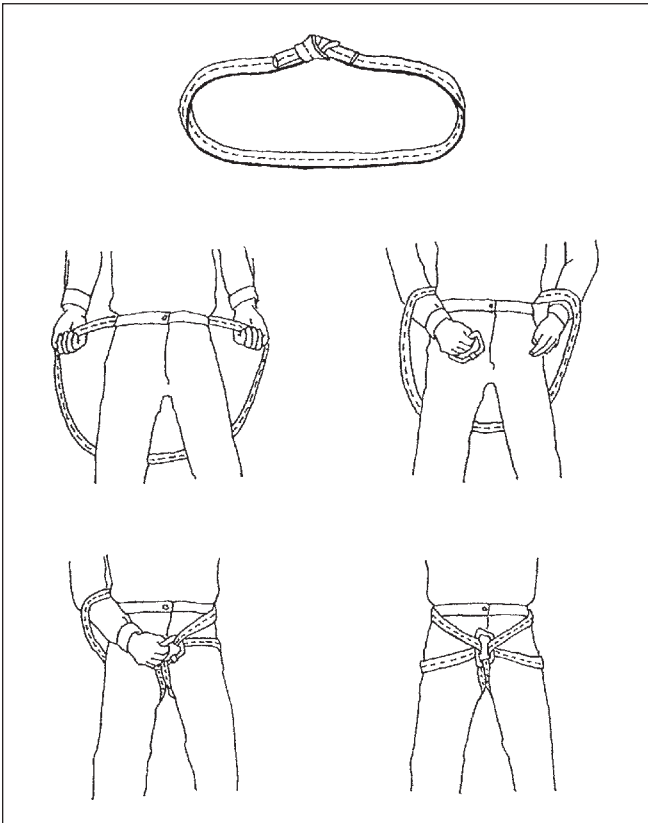

Figure 7b—Constructing the diaper sling. Tails should be long enough to tie off with an overhand knot.

The body harness has three parts:

1. Chest harness.
2. Swami belt (A piece of webbing tied around the waist using a water knot.) The belt is used for extra support with the chest harness and diaper sling.
3. Diaper sling.

7.2 Rescue Procedures

The ground person must follow this sequence of actions (in order) when aiding a climber incapacitated in a tree:

1. Make a quick assessment of the incident from the ground.
2. Call or send for assistance.
3. Ground all climbers in the area and have them report to your location.
4. Develop a plan of action appropriate for the incident.
5. Climb to the victim's location.
6. Provide immediate first aid.
7. Extract the victim.

7.2.1 Assessing the Incident

1. Attempt to assess the victim's situation from the ground.
 - A. Is the victim breathing?
 - B. Is the victim bleeding profusely?
 - C. Is the victim conscious and responsive?
 - D. Is the victim secured (by a lanyard or safety line)?
 - E. What is the victim's apparent emotional stability?
2. Assess your ability to make an immediate rescue.
 - A. Who is available to help?
 - B. What equipment is on hand?
 - C. What is the rescue proficiency of the available personnel?

3. Assess your needs for assistance.
 - A. What resources are on call (such as emergency medical technicians, fire departments, ambulances, and search and rescue organizations)?
 - B. What is the anticipated response time?
 - C. What is the potential for the situation to deteriorate while you are waiting for assistance?

7.2.2 Requesting Assistance

Call or send for assistance. A radio chest harness worn over the safety harness allows the ground person to be in constant contact with support personnel while continuing to help the injured climber.

1. Do not leave an incapacitated climber alone, if possible. If you must leave, make sure the climber understands why you are leaving and when you will return. Make sure your absence is as short as possible. If your only option is to leave your team member unattended, you were not adequately prepared.
2. While assessing the incident, consider requesting that support personnel and resources be activated to standby status.
3. Before seeking help, think over the whole situation and take time assess all the facts. If possible, write down some information before making the call, including:
 - A. Extent of injuries.
 - B. Exact location.
 - C. Personnel, food, and equipment on the scene.
 - D. Probable time to reach the scene by ground.
 - E. Type of terrain.
 - Is a helispot nearby? If so, what is its exact location?
 - Is the terrain favorable for smokejumpers? If the location is remote, seriously consider using smokejumpers because of their skill and training in this type of rescue.
 - F. Special markings (such as flagging) or landmarks from the road or trail to the scene of the incident.
 - G. When, where, and how support personnel will contact the rescuer.

The ground person may need to begin rescue before help arrives if the victim is not or cannot be secured in the tree or requires treatment that cannot be provided in the tree.

7.2.3 Grounding All Climbers In the Area

When notified of an accident in the area, all climbers should return to the ground and proceed to the scene to lend their assistance. Once enroute, climbers should radio dispatch to report their estimated time of arrival at the accident site, if possible.

7.2.4 Developing a Plan of Action

Before attempting a rescue, take a minute to develop a plan of action for the incident. Unforeseen problems or changes in the victim's condition or the environment may require you to modify your plan. Do not unnecessarily jeopardize your safety to save someone if more qualified help is available in an acceptable amount of time.

1. Ascending to the victim
 - A. Use the most efficient ascending method available to reach the incapacitated climber. This could include climbing sectional ladders that are already in place, using climbing spurs, or climbing a fixed rope with ascenders. Do not ascend the tree directly below the victim if there is any doubt about how well the victim is secured to the tree. The rescuer's first responsibility is personal safety. If the victim is above the level in the tree that can safely support your weight and the victim's, proceed as follows:
 - (1) Climb to a safe level.
 - (2) If the victim appears to be conscious, encourage the victim to move to your location. If the victim does not respond immediately and does not need emergency first aid, keep trying to awaken the victim without leaving your location.
 - (3) If the victim does not respond or needs emergency first aid, attach a safety line to the tree bole at a safe level and proceed toward the victim on the OPPOSITE side of the tree bole (to balance the weight on the bole). Make sure the victim's safety line is secured to the bole at a safe level.
 - B. After reaching the victim, immediately secure yourself to the tree, then secure the victim to the tree, if necessary. Ensure that the victim is not suspended vertically.
 - C. Provide emergency first aid as needed.
 - D. All climbers should wear a safety harness suitable for rescue whenever climbing or working in trees.

7. Rescue

Circumstances may require a rescuer to use materials on hand to improvise or repair a safety harness.

2. Securing the victim to a second safety line

Secure the injured climber in a comfortable upright position with a safety line. This provides additional safety for the injured climber in case the original support system was damaged by the accident.

- A. Use a tensionless hitch to secure a safety line to the bole below the 4-inch-stem-diameter level and above a whorl of stout branches (see figure 6a).
- B. Pass the free end of the line through the chest harness carabiner, through the swami belt carabiner, and finally through the diaper sling carabiner (or corresponding points on the climbing harness).
- C. After taking slack out of the safety line, secure the line to the bole below the point where the other end is secured. Always tie the safety line onto the bole out of reach of the incapacitated climber.

A Z-rig pulley system may also be used (figure 7c). The Z-rig pulley system consists of two pulleys slung separately around the tree above the victim and a pulley on the victim's harness; the working end of the rope is secured to the victim's harness. Carabiners can be substituted for the pulleys, but will add friction to the system.

- D. No person should be left hanging by a waist belt for an extended period of time because pain, numbness, respiratory distress, change in blood pressure and pulse, shaking, loss of consciousness, and death may result. All climbers should wear a harness that provides chest and pelvic support. Keep the victim's legs bent to avoid suspension trauma.

Only those climbers absolutely needed for initial assessment should climb to the victim. The rescuer should be able to perform whatever treatment is necessary.

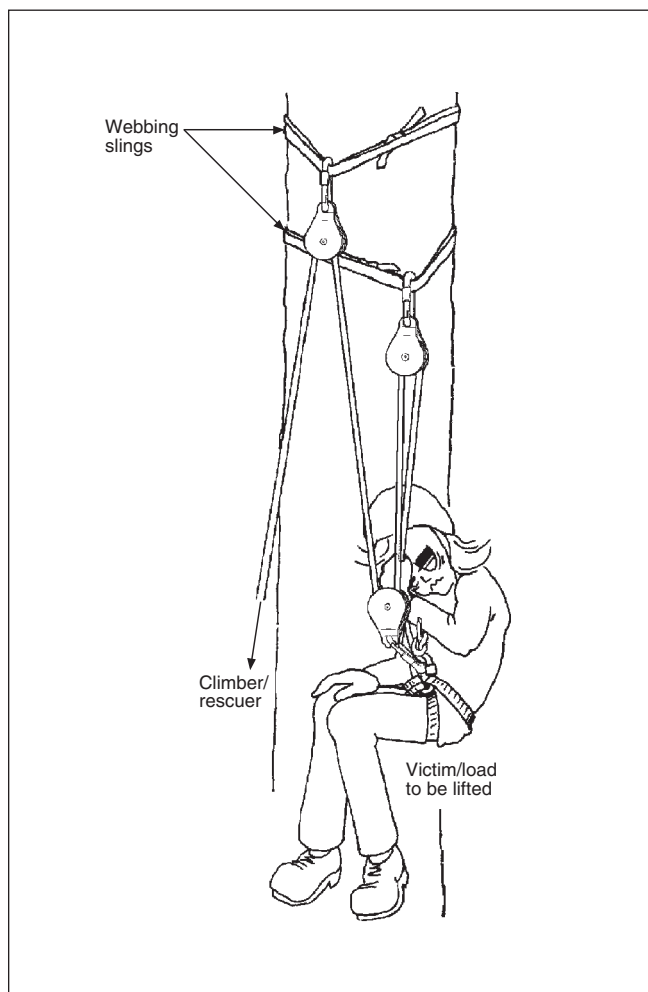

Figure 7c—A Z-rig pulley system for lowering a victim from a tree.

7.2.5 Providing Immediate First Aid

Assess the ABCs (airway, breathing, circulation) and secure the victim's airway, if necessary. Mouth-to-mouth resuscitation and CPR cannot be performed in the tree; if necessary, get the victim to the ground as fast as possible regardless of the extent of injuries.

7.2.6 Extricating the Victim

Decide whether or not to extricate the victim without additional assistance.

1. It is almost always best to obtain assistance before moving a victim unless one or more of the following is true:
 - A. The victim's position in the tree is precarious.

-
- B. The victim's medical condition requires immediate care that can only be provided on the ground.
 - C. The victim is physically and mentally able to assist the rescuer.
 - D. The rescuer's level of rescue preparation makes the current situation straightforward and low risk.
2. Protect the victim from further injury before performing the rescue.
 - A. Provide emotional support to the injured, anxious victim.
 - B. Continue checking the ABCs (airway, breathing, circulation).
 - C. Clear a path for lowering the victim.
 3. **If the injury is not life threatening and the victim can be secured safely in the tree, wait for help to bring the victim down.**
 4. If the injury is life threatening, perform the rescue immediately.
 - A. Secure a lowering rope to the tree about 10 feet or more above the victim.
 - B. Attach a rappel device to the lowering rope and secure yourself to it. Any of the recommended rappel systems can be used to lower a severely injured climber.
 - C. Rappel to the victim. This assures you and the victim that the lowering rope is secured and the rappel device is working. It also provides for your safety at all times and allows you to approach the victim while already secured on the rope.
 - D. After doublechecking the system, gently transfer the victim's weight to the rappel device using webbing and carabiners by slowly releasing the lower end of the safety line. The victim should be placed in

a position that provides for the safety of both the rescuer and the victim and that allows the rescuer to care for the victim. The type of equipment the victim has on can provide various options for positioning the victim.

- *Victim in rescuer's lap.* The victim can be positioned in the rescuer's lap below the descender, but resting on the rescuer's legs. This position enables the rescuer to control the victim's arms and legs and talk directly to the victim, but can interfere with the rescuer's control of the rope. This may be the preferred method for rescuing an unconscious victim when little or no help is available. However, the harnesses used by the victim and rescuer may not make this method feasible.
 - *Victim hanging below rescuer.* Positioning the victim below the rescuer enables the rescuer to control the descent without interference, but the victim can cause problems by grabbing the tree or the ropes and the victim may have trouble descending because of interference from tree branches. Another rescuer descending alongside the victim may be needed to keep the victim clear of obstructions. Keep the victim's legs bent slightly to avoid suspension trauma.
- E. Maintain control of the rappel device tie-off if there is any likelihood of interference from the victim.
 - F. Descend to the ground, manipulating the support system and guiding the victim past any obstacles.
 - G. Provide additional first aid as needed, and prepare the victim for transport to a medical facility. If the victim is unconscious and suspension trauma is possible, keep the victim in a seated or reclining position for a period of time before repositioning the victim to a prone position.

7. Rescue—Notes

8. Equipment Specifications

All equipment used for climber support shall meet or exceed ANSI standards for breaking strength. This requirement is consistent with search and rescue requirements for a 15:1 safety margin. Haul lines should be capable of supporting items being hauled into the tree and lowered from the tree without exceeding their working-load limits.

8.1 Carabiners and Screw Links

Carabiners used in life-support applications shall be of the self-closing, positive-locking type, and along with screw links, shall have a minimum tensile strength of 5,000 pounds or 22kN. Standard one-quarter-turn, twistlock carabiners do not have a positive-locking mechanism and shall not be used in life-support applications.

8.2 Climbing Belts and Safety Harnesses

Climbing belts and safety harnesses shall meet the requirements of ANSI A10.14.

8.3 Climbing Helmets

Helmets used for tree climbing shall be UIAA (Union Internationale des Associations d'Alpinisme) approved. These helmets have been tested for side impact and puncture resistance, shock absorption, and the ability to remain on the head during impact. Helmets certified for search and rescue operations, or those certified as meeting ANSI Standard Z89.1 Type II, which are equipped with a three-point harness, are also acceptable. The most desirable of these helmets have an adjustable suspension system and shock-absorbing foam padding.

8.4 Ropes

Ropes used for safety lines, safety straps, lanyards, and climbing lines should have an abrasion resistance and a melting point that is equal to or greater than nylon rope and a minimum breaking strength (dry test) of 5,400 pounds. Climbing lines that are UIAA approved and meet the standard for single-rope use are suitable. Smaller diameter rope of less than 5,400-pounds breaking strength may be used to construct slings and Prusik loops if the finished product meets or exceeds 5,400-pounds breaking strength; however, the margin of safety will be lower because the smaller diameter rope will have less resistance to friction wear for these purposes.

8.5 Webbing

Tubular webbing used for safety straps or slings should have a spiral structure (shuttle loom construction) or meet class 1A of MIL-W-4088 (military specifications for tubular needle loom construction). Webbing should have a breaking strength (dry test) of at least 5,400 pounds. It is acceptable to use webbing with less strength if the safety strap or sling is constructed to form a finished product with at least a 5,400-pound minimum breaking strength (figure 3t).

8.6 Miscellaneous Hardware

Other miscellaneous hardware used for life support in tree climbing work shall have a minimum breaking strength of 5,000 pounds or 22kN.

8. Equipment Specifications—Notes

9. Handling Materials and Tools While in Trees

Always maintain control of your materials and tools while working in a tree. Loss of control can cause you to lose your balance and precipitate a fall or injure the ground person. Follow these procedures when handling materials and tools while working in a tree:

1. Keep ground personnel clear of the tree unless they are assisting the climb, in which case they should wear climbing helmets. As the climber, it is critical that you are aware of all ground personnel to minimize any potential hazard. Ground personnel should never be directly underneath a climber unless they are assisting the climber and have been cleared by the climber to be there.
2. Keep hands free of materials and tools while climbing.
3. Use a haul line with suitable working-load strength to raise and lower items that could hinder climbing activities. Place other items in your pockets or secure them to your climbing belt or safety harness.
4. Keep protective coverings (sheaths) over sharp edges and pointed tips of equipment that are not in use.
5. Keep tools and materials secured firmly to you or the tree. Whenever possible, secure large tools to the tree.
6. Hand saws used for pruning should have a blade that folds into the handle, completely covering the teeth and saw blade tip, or a snug sheath to protect the saw when it is not in use. Pruning shears are best for cutting small branches.
7. When using cutting tools of any kind (except pruning shears), secure yourself to the tree with at least two lanyards, one of which should be a steel cable or steel-core lanyard.

9.1 Pruning Branches

Prune large branches (about 1½ inches in diameter at the bole or larger) as follows:

1. Undercut the branch about a foot from the bole. The undercut should reach about halfway through the branch.
2. Topcut the branch down to the undercut.
3. Allow the branch to free fall to the ground. If necessary, lower the branch with a haul line (figure 9a). Follow these procedures when using a haul line:
 - A. Pass a haul line around the bole above a whorl of branches and tie it off with a clove hitch on a bight. This attachment point should be above you. Allow enough rope at the working end so that the branch

will fall several feet below you before being stopped by the haul line. Always keep the haul line clear of you and your climbing equipment.

- B. Attach the working end of the rope to the branch about 1 foot out from the cut.
 - C. Make the cut as described above.
 - D. Allow the branch to free fall against the haul line.
 - E. Untie the clove hitch on a bight by pulling the bight out of the hitch. This will create additional slack and the limb will fall farther. Maintain control of the haul line while untying the clove hitch.
 - F. Lower the cut branch (you or your ground person can do so), maintaining control by adjusting the amount of friction being applied by the bight around the tree bole.
4. Prune the stub by undercutting about one-quarter of the way through the stub and then topcutting down to the undercut. These cuts should be flush with the outside edge of the branch collar.
 5. Allow the stub to free fall, or lower it to the ground with a haul line as described above.

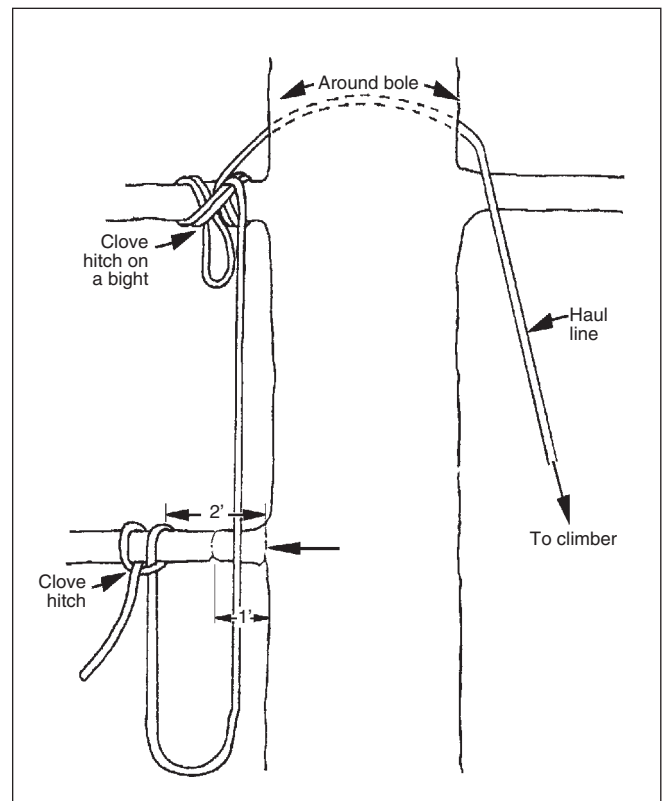

Figure 9a—Using a haul line to lower pruned branches.

9.2 Harvesting Seed

Use picking containers to lower seed-bearing fruit and cones gently to the ground. Always secure heavily loaded containers to the tree and not to yourself. A haul line that is looped around the bole over a whorl of branches and attached to the picking container makes it easier to handle heavy containers. Secure the standing part of the haul line to a branch with a clove hitch on a bight or other suitable knot, allowing the container to hang unattended.

When the container needs to be lowered to the ground or to another picking spot, untie the knot and gently lower the container using the friction of the haul line around the bole to control the rate of descent. The pulley haul system is an option for lowering containers. Loads can be easily controlled by the ground person. However, if a pulley system is used, the climber must ascend the tree to retrieve or reposition the pulley.

You may also use small, light containers for picking and transfer the contents to larger containers on the ground. Use a haul line to gently lower picking containers holding fruit or cones to the ground (figure 9b).

Another acceptable procedure is to allow cones and seed-bearing fruit to free fall to the ground, exercising care to avoid hitting ground crews with cones. Ground tarps greatly speed up the gathering process.

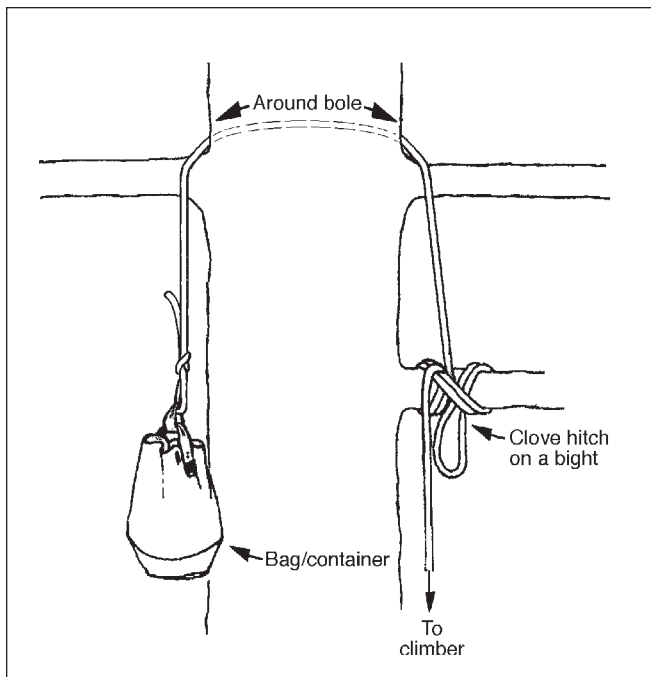

Figure 9b—Using a haul line to lower bags or containers.

9.3 Harvesting Scion Material for Grafting

Scion material (cuttings used for grafting) may be individually harvested and placed in a collection bag or allowed to free fall to the ground for harvesting. The tree may also be topped, and the scion material harvested on the ground. When topping a tree, the bole should be properly undercut so that the top falls free of the climber. A treetop may be allowed to free fall to the ground, or if the treetop is small, it may be lowered to the ground by a haul line using the following procedure (figure 9c):

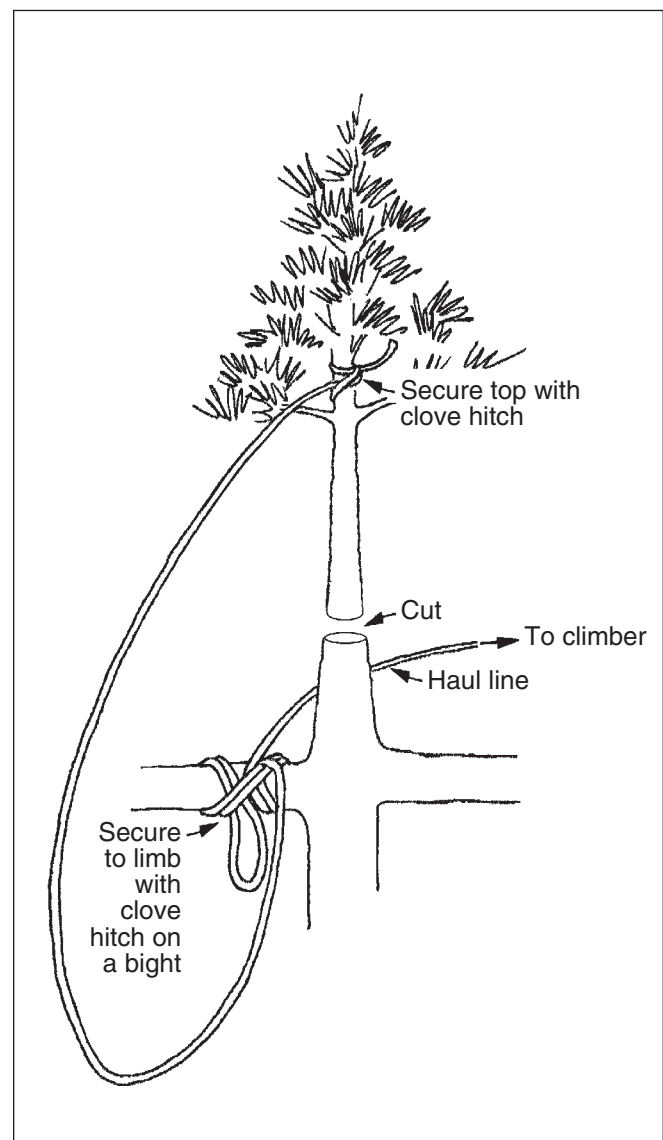

Figure 9c—Using a haul line to lower treetops.

1. Pass a haul line around the bole above a whorl of branches and tie it off with a clove hitch on a bight. This attachment point should be just below your position when making the topping cuts. Allow enough rope at the working end so the rope can be attached to the treetop above a whorl of branches and the treetop can fall several feet below you before being stopped by the haul line.
2. Attach the working end of the rope to the treetop just above a whorl of branches located above the topcut location. Always keep the haul line clear of you and your climbing equipment during the next steps.
3. Make the topcut according to established procedures.
4. Allow the cut treetop to free fall against the haul line.
5. Untie the clove hitch on a bight by pulling the bight out of the hitch. This will cause additional slack and the limb will fall farther. Maintain control of the haul line while untying the clove hitch.
6. Maintain control while lowering the cut treetop to the ground by adjusting the amount of friction being applied by the bight around the bole.

9. Handling Materials and Tools While in Trees—Notes

10. References

Much of the technical information in this field guide is derived from the following sources. Climbers and climbing instructors are strongly encouraged to refer to these references for additional information about equipment, procedures, and safety.

- Ashley, Clifford W. 1944. *The Ashley book of knots*. Garden City, New York: Doubleday & Co. 620 p.
- Beranek, G.F. *The fundamentals of general tree work*. Ft. Bragg, CA: Beranek Publications. 512 p.
- Denison, W.C.; Tracy, D.M.; Rhoades, F.M. 1972. Direct, nondestructive measurements of biomass and structure in living, old-growth Douglas-fir. *Proceedings—Research on coniferous forest ecosystems—a symposium*. Portland, OR: U.S. Department of Agriculture, Forest Service, Pacific Northwest Forest and Range Experiment Station. 147–158.
- Frank, James A.; Smith, Jerry. 1983. Figure eight descenders. *Nylon Highway*. Huntsville, AL: National Speleological Society Vertical Section. 16:1–4; June.
- Frank, James A.; Smith, Jerrold B. 1987. *Rope rescue manual*. Santa Barbara, CA: California Mountain Co., Ltd. 138 p.
- Graumont, Raoul. 1945. *Handbook of knots*. Cambridge, MD: Cornell Maritime Press, Inc. 194 p.
- Graydon, Don, ed. 1997. *Mountaineering: the freedom of the hills*. 6th ed. Seattle, WA: The Mountaineers. 544 p.
- Hudson, Steve; Williams, Toni. 1983. Using the rappel rack. *Nylon Highway*. Huntsville, AL: National Speleological Society Vertical Section. 16: 5–14; June.
- Jepson, Jeff. 1997. *The tree climber's companion*. Longville, MN: Beaver Tree Publishing. 54 p.
- Lilly, Sharon. 1998. *Tree climber's guide*. International Society of Arboriculture. Hagerstown, IN: Exponent Publishers, Inc. 143 p.
- Martin, Tom. 1988. *Rappelling edition II*. Mt. Sterling, KY: Search. 295 p.
- National Fire Protection Association (NFPA) 1983. 2001. *Standard on fire service life safety rope and system components*. Quincy, MA: National Fire Protection Association. 34 p.
- OSHA Standards Handbook H6109.13.
- Padgett, Allen; Smith, Bruce. 1996. *On rope: North American vertical rope techniques*. Huntsville, AL: National Speleological Society. 382 p.
- Seal, D.T.; Matthews, J.D.; Wheeler, T.T. 1962. *Collection of cones from standing trees*. Forest Record No. 39. England: Forestry Commission. 45 p.
- Setnicka, Tim J. 1980. *Wilderness search and rescue*. Boston, MA: Appalachian Mountain Club. 640 p.
- Snyder, E.B.; Rossoll, H. 1958. *Climbing southern pines safely*. U.S. Department of Agriculture, Forest Service, Southern Forest Experiment Station. Occasional Pap. 159. 17 p.
- Vines, Tom; Hudson, Steve. 1989. *High angle rescue techniques: a student guide for rope rescue classes*. National Association for Search and Rescue. Dubuque, IA: Kendall/Hunt Publishing. 250 p.
- Wellington-Puritan, Inc. 1980. *The splicing book*. Madison, GA: Wellington-Puritan, Inc. 18 p.
- Wheelock, W. 1967. *Ropes, knots, and slings for climbers*. Glendale, CA: La Siesta Press. 36 p.
- Yeatman, C.W.; Nieman, T.C. 1978. *Safe tree climbing in forest management*. Forestry Tech. Rep. 24. Fisheries and Environment Canada, Forestry Service. 34 p.

10. References

Climbing Equipment Manufacturers and Distributors —This list of climbing equipment dealers is not complete.

Manufacturer/Distributor	Equipment Offered
American Safety and Rescue 4129 State St., Suite H Santa Barbara, CA 93110 Phone: 805-681-1338	High-angle climbing and rescue equipment
Ben Meadows Co. P.O. Box 80549 Atlanta, GA 30366 Phone: 800-241-6401	Harnesses, safety belts, lanyards, ropes, carabiners, rappel devices, spurs, ladders, Swiss Tree Grippers, chain steps
Blue Water Ropes & Equipment 209 Lovvorn Rd. Carrollton, GA 30117 Phone: 404-834-7515	Harnesses, ropes, carabiners, rappel devices, webbing, rope bags, nylon haul lines, ascenders, pulleys, slings, belay plates, BW rappel racks
Bob & Bob Enterprises P.O. Box 441 Lewisburg, WV 24901 Phone: 304-772-5049/3074	Ropes, carabiners, rappel devices, climbing helmets, webbing, ascenders, nylon haul lines, pulleys, rope bags, Seattle Manufacturing Corp. (SMC) rappel rack, climbing books
California Mountain Co., Ltd. (CMC) P.O. Box 6870 Santa Barbara, CA 93160-6870 Phone: 800-235-5741	Harnesses, ropes, carabiners, rappel devices, ascenders, pulleys, webbing, rope bags, climbing helmets, climbing and rescue books, Seattle Manufacturing Corp. (SMC) rappel rack
Descent Control, Inc. P.O. Box 6405 Fort Smith, AR 72906 Phone: 800-643-2539	Harnesses, safety belts, lanyards, ropes, carabiners, rappel devices (Sky Genie), tree-crotch lanyards
Forestry Suppliers P.O. Box 8397 Jackson, MS 39284 Phone: 800-647-5368	Harnesses, safety belts, lanyards, ropes, ladders, Swiss Tree Grippers, nylon haul lines
Graybar Electric P.O. Box 13159 Portland, OR 97213 Phone: 503-249-1300	Pole steps (⁵ / ₈ by 10 inches, A.B. Chance, part No. 506125)
Klein Tools 7200 McCormick Rd. Chicago, IL 60645 Phone: 312-677-9500	Harnesses, safety belts, spurs
Liberty Mountain Sports P.O. Box 306 Montrose, CA 91020 Phone: 800-366-2666	Harnesses, ropes, carabiners, rappel devices, ascenders, nylon haul lines, webbing, pulleys, climbing helmets, belay plates, rescue rappel racks
Mallory Company 1814 Baker Way Kelso, WA 98626 Phone: 800-426-6830	Harnesses, safety belts, ropes, rappel devices, spurs, tree-crotch lanyards

Manufacturer/Distributor	Equipment Offered
New Tribe 5517 Riverbanks Rd. Grants Pass, OR 97527 Phone: 866-223-3371	Harnesses, lanyards, ropes, carabiners, rappelling devices, ascenders, miscellaneous recreational climbing equipment.
REI (Recreational Equipment, Inc.) P.O. Box 88125 Seattle, WA 98138-0125 Phone: 800-426-4840	Harnesses, ropes, carabiners, rappel devices, climbing helmets, webbing
Rescue Response Gear P.O. Box 1148 Bend, OR 97709-1148 Phone: 800-400-8158	High-angle climbing and rescue equipment
Rescue Systems, Inc. Highway 95, Box RSI Lake Powell, UT 84533-0110 Phone: 800-552-1133	High-angle climbing and rescue equipment
Rescue Technology P.O. Box 1465 131 Lovvorn Rd. Carrollton, GA 30117 Phone: 770-832-9694	High-angle climbing and rescue equipment
Rock-N-Rescue P.O. Box 213 Valencia, PA 16059-0213 Phone: 800-346-7673	High-angle climbing and rescue equipment
Sherrill, Inc. 3101 Cedar Park Rd. Greensboro, NC 27405 Phone: 800-525-8873	Harnesses, lanyards, ropes, carabiners, rappelling devices, spurs, ascenders, etriers, miscellaneous arborist equipment, books
Sierra Moreno Mercantile Co. P.O. Box 292 Big Pool, MD Phone: 800-262-0800	Microjuster lanyards, steel core lanyards
Smith Safety Products, Inc. P.O. Box 36 Petaluma, CA 94953 Phone: 800-772-5948	High-angle climbing and rescue equipment
WesSpur, Inc. 2111 Lincoln St. Bellingham, WA 98225 Phone: 800-268-2141	Harnesses, lanyards, ropes, carabiners, rappelling devices, spurs, ascenders, etriers, miscellaneous arborist equipment, books

10. References—Notes

Library Card

Davis, Dennis. 2005. National tree climbing field guide: 2005 edition. Tech. Rep. 0567-2819-MTDC. Missoula, MT: U.S. Department of Agriculture, Forest Service, Missoula Technology and Development Center. 88 p.

Describes procedures used by Forest Service employees when climbing trees. Topics covered include: preparing for a climb; ropes, knots, splices, and webbing; climbing safety—equipment, systems, and procedures; climbing equipment—use and care; rappel systems—use and care; rescue; equipment specifications; and handling materials and tools while in trees.

Keywords: ascenders, equipment, knots, rappelling, ropes, safety, safety at work

Additional single copies of this document may be ordered from:

USDA Forest Service
Missoula Technology and Development Center
5785 Hwy 10 West
Missoula, MT 59808-9361
Phone: 406-329-3978
Fax: 406-329-3719
E-mail: wo_mtdc_pubs@fs.fed.us

For information regarding this guide, contact Dennis Davis at the address above.

Phone: 406-329-3929
Fax: 406-329-3719
E-mail: ddavis@fs.fed.us

Electronic copies of MTDC's documents are available on the Internet at:

<http://www.fs.fed.us/eng/t-d.php>

Forest Service and Bureau of Land Management employees can search a more complete collection of MTDC's documents, videos, and CDs on their internal computer networks at:

<http://fsweb.mtdc.wo.fs.fed.us/search>